

# CALENDAR FOR THE ACADEMIC YEAR 2017

## SPRING SEMESTER (April 1- September 20, 2017)

2017

<b>APRIL</b>	
1 (SAT)	Entrance ceremony for new degree students Orientation for new students (degree) English placement test
2(SUN)-12 (WED)	Course registration (sophomores, juniors, seniors)
2 (SUN)-7 (FRI)	First lottery registration (sophomores, juniors, seniors)
3 (MON)	Orientation for new exchange students Orientation for new non-degree students Japanese placement test Chinese, French and Spanish placement interview
3 (MON)-12 (WED)	Course registration (freshmen, exchange/non-degree students)
3 (MON)-7 (FRI)	First lottery registration (freshmen, exchange/non-degree students)
4(TUE)	Guidance for transfer students
5 (WED)-6 (THU)	Orientation camp for new degree students
7 (FRI)	Individual advising for all students
8 (SAT)	Results of first lottery registration available on Loyola
8 (SAT)-9 (SUN)	Second lottery registration
10 (MON)	Results of second lottery registration available on Loyola
10(MON)-12 (WED)	Final lottery registration (first-come-first-served basis)
12 (WED)	Classes begin
13 (THU)	Results of course registration available on Loyola
14 (FRI)	Early graduation application deadline (for September graduation)
14 (FRI)-16 (SUN)	Course adjustment period
18(TUE)	Final confirmation of course registration available on Loyola
19 (WED)-21 (FRI)	Cancellation period
<b>MAY</b>	
2 (TUE)	Tuition bill sent
16 (TUE)	Tuition payment deadline
31 (WED)	Leave of absence application deadline
<b>JUNE</b>	
5 (MON)-9 (FRI)	Withdrawal period
8 (THU)	Sophomore guidance
17 (SAT)	Make-up classes
25 (SUN)	Make-up classes
<b>JULY</b>	
1 (SAT)	Make-up classes
10 (MON)	Final exam schedule available on Loyola
15 (SAT)	Make-up classes
17(MON)	Classes to be held
22 (SAT)	Final day of classes
24(MON)-29 (SAT)	Final examinations [Extra day: JUL 29 (SAT)]
20 (THU)-AUG 11 (FRI)	Summer Session in Asian Studies Course registration: JUN 12 (MON)-16 (FRI) Final examination: AUG 11 (FRI)
31(MON)-SEP 26 (TUE)	Summer recess
<b>AUGUST</b>	
28 (MON)	Grades available on Loyola (for seniors and graduating students)
28 (MON)-29 (TUE)	Deadline for request for grade review (for seniors and graduating students)
mid to late August	Make-up examinations
<b>SEPTEMBER</b>	
8 (FRI)	Announcement of graduating students on Loyola
9 (SAT)	Grades/Self-evaluation/Category change available on Loyola (juniors)
10 (SUN)	Grades/Self-evaluation/Category change available on Loyola(sophomores)
11 (MON)	Grades/Self-evaluation/Category change available on Loyola (freshmen, exchange / non-degree students)
15 (FRI)	Graduation ceremony
20 (WED)	Deadline for request for grade review (for 2017 spring courses)

**AUTUMN SEMESTER (September 21, 2017- March 31, 2018)****2017**

<b>SEPTEMBER</b>	
21 (THU)	Entrance ceremony for new degree students Orientation for new students (degree, non-degree, exchange) English placement test Chinese, French and Spanish placement interview
22 (FRI)	Japanese placement test Guidance for transfer students
24 (SUN)-25 (MON)	Orientation camp for new degree students
21 (THU)-30 (SAT)	Course registration (sophomores, juniors, seniors)
22 (FRI)-30 (SAT)	Course registration (freshmen, exchange/non-degree students)
21 (THU)-25 (MON)	First lottery registration (sophomores, juniors, seniors)
22 (FRI)-25 (MON)	First lottery registration (freshmen, exchange/non-degree students)
26 (TUE)	Results of first lottery registration available on Loyola
26 (TUE)-27 (WED)	Second lottery registration
26 (TUE)	Individual advising for all students
27 (WED)	Classes begin
28 (THU)	Results of second lottery registration available on Loyola
28 (THU)-30 (SAT)	Final lottery registration (first-come-first-served basis)
<b>OCTOBER</b>	
1 (SUN)-2 (MON)	Results of course registration available
3 (TUE)-5 (THU)	Course adjustment period
5 (THU)	Early graduation application deadline (for March graduation)
9 (MON)	Final confirmation of course registration available on Loyola Classes to be held
10 (TUE)-12 (THU)	Cancellation period
19 (THU)	Tuition bill sent
<b>NOVEMBER</b>	
2 (THU)	Tuition payment deadline
23 (THU)	Classes to be held
30 (THU)	Leave of absence application deadline
<b>DECEMBER</b>	
4 (MON)-8 (FRI)	Withdrawal period
7 (THU)	Sophomore guidance
9 (SAT)	Make-up classes
16 (SAT)	Make-up classes
22 (FRI)-JAN 4 (THU)	Winter recess
<b>2018</b>	
<b>JANUARY</b>	
5 (FRI)	Classes resume
9 (TUE)	Final exam schedule available on Loyola
6 (SAT)	Make-up classes
13 (SAT)	Make-up classes
22 (MON)	Final day of classes
23 (TUE)-30 (TUE)	Final examinations [Extra day : JAN 30 (TUE)]
31 (WED)-MAR 31 (SAT)	Spring recess
<b>FEBRUARY</b>	
mid to late February	Make-up examinations
23 (FRI)	Grades available on Loyola (for seniors and graduating students)
23 (FRI)-27 (TUE)	Deadline for request for grade review (for seniors and graduating students)
<b>MARCH</b>	
15 (THU)	Announcement of graduating students on Loyola
16 (FRI)	Grades/Self-evaluation/Category change available on Loyola (juniors)
17 (SAT)	Grades/Self-evaluation/Category change available on Loyola (sophomores)
18 (SUN)	Grades/Self-evaluation/Category change available on Loyola (freshmen, exchange/non-degree students)
26 (MON)	Graduation ceremony
30 (FRI)	Deadline for request for grade review (for 2017 autumn courses)

---

## **HOLIDAYS AND NO-CLASS DAYS**

Spring Semester:

May 3 (Wed)	Constitution Memorial Day (National Holiday)
May 4 (Thu)	Greenery Day (National Holiday)
May 5 (Fri)	Children's Day (National Holiday)

Autumn Semester:

November 1 (Wed)	Foundation Day / Memorial Service (School Holiday)
November 2 (Thu)	School Holiday
November 3 (Fri)	Culture Day (National Holiday)
December 3 (Sun)	St. Xavier's Day (School Holiday)
January 8 (Mon)	Coming of Age Day (National Holiday)

---

## **CLASS HOURS**

1st Period : 9:15 – 10:45
2nd Period : 11:00 – 12:30
3rd Period : 13:30 – 15:00
4th Period : 15:15 – 16:45
5th Period : 17:00 – 18:30
6th Period : 18:45 – 20:15

---

## **CLASS CANCELLATIONS**

Classes are normally held according to the academic calendar, but they may be canceled due to an academic conference, business trip or illness of a faculty member. Class cancellations are announced on Loyola\* when the teacher notifies the Center for Academic Affairs. An announcement may be posted on Loyola on the same day a class is canceled, so please make it a habit to check Loyola before each class. You may also check for class cancellations on the day of the class from your mobile phone.

If a faculty member does not come to class within 30 minutes of the starting time, please notify the Center for Academic Affairs and follow their instructions.

---

## **MAKE-UP CLASSES**

Make-up classes are normally held on predetermined dates scheduled in the Spring and Autumn semesters, but other days may also be arranged for make-up classes. In both cases, the days for make-up classes will be announced on Loyola; please check the date, time, and classroom.

---

Class cancellations, make-up classes or any additional no-class days will be announced on the Loyola Bulletin Board.
--

\*Loyola Web Service: see section a.130

**SOPHIA UNIVERSITY**

**FACULTY OF LIBERAL ARTS**

**BULLETIN OF INFORMATION**

**2017-2018**

**Bulletin of Information 2017-2018**  
**Faculty of Liberal Arts**  
**Sophia University**  
**The Office of the Faculty of Liberal Arts**  
**7-1 Kioi-cho, Chiyoda-ku, Tokyo 102-8554, Japan**  
**Telephone       03 (3238) 4004**  
**Fax               03 (3238) 4076**

**Published by the Center for Academic Affairs,**  
**Sophia University**

**7-1 Kioi-cho, Chiyoda-ku, Tokyo 102-8554, Japan**  
**Telephone       03 (3238) 3515**  
**Fax               03 (3238) 3264**

**March, 2017**

---

Every effort is made to ensure the accuracy of the information contained herein. However, subsequent to the date of publication, circumstances may necessitate changes. The University reserves the right to make all such changes, including those in the program of study, courses of instruction, fees, and officers of administration and instruction, without notice.

---

# TABLE OF CONTENTS

## Table of Contents

INTRODUCTION P. 2

SECTION A: REGULATIONS AND PROCEDURES P. 3

- § a100 General Information for FLA Students P. 3
- § a200 Degree Requirements P. 5
- § a300 Course Registration P. 8
- § a400 Examinations P. 14
- § a500 Grades P. 19
- § a600 Change in Student Status P. 21
- § a700 Study Abroad Programs P. 24
- § a750 Certification Programs P. 25
- § a800 Tuition and Fees P. 26
- § a900 Announcements from University Offices P. 28

SECTION B: FLA CURRICULUM P. 35

- § b010 Information on Curriculum P. 35
- § b100 Curriculum for Students who Entered from 2014 P. 37
- § b200 Curriculum for Students who Entered before 2014 P. 61
- § b300 Course Lists P. 85

SECTION C: SUMMER SESSION & CERTIFICATE PROGRAMS P. 95

- § c100 Summer Session P. 95
- § c200 Certificate Programs P. 96

SECTION D: INFORMATION ON INSTRUCTORS & OFFICES P. 99

- § d100 Teaching Staff and Faculty Office Hours 2017-2018 P. 103
- § d200 General Information and Office Directory P. 104
- § d300 Campus Map P. 107

INDEX P. 117

## §1 INTRODUCTION

### **The Educational Ideals of Sophia University**

Based on Christian principles of education, Sophia University attests to the four-hundred-year-old interest of the Jesuit Order in Japan. Its aim is to prepare men and women coming from different countries to recognize in the different cultural traditions of the world the fundamental unity of the human race and to work for the concrete achievement of that unity. The roots of the university go back to 1549, when St. Francis Xavier, a Jesuit, landed in Kagoshima with the hope of starting a Catholic university which would introduce Western culture to Japan. In 1908, nearly 360 years later, three members of the Society of Jesus—the German Father Joseph Dahlmann, the French Father Henri Boucher, and the English Father James Rockliff—came to Japan with the mission of fulfilling St. Francis Xavier’s aspiration. As a result of their efforts, Sophia University was established in 1913, when the Japanese Ministry of Education gave the Jesuits permission to found a new educational institution under the Japanese name of Jōchi Gakuin. Sixteen students enrolled in the first class. From this modest beginning Sophia University has grown to be one of the foremost of Japan’s private universities, with a student body of over 12,000 undergraduate and graduate students and a teaching staff of more than one thousand. In the tradition of the international character of Sophia’s founders, the faculty members represent twenty different nationalities; they are committed to conveying to the next generation through their scholarship and teaching both humankind’s cultural and intellectual heritage and a concern for the problems facing the world today.

### **The Faculty of Liberal Arts**

The Faculty of Liberal Arts (FLA) continues in a new form the educational approach and goals established by its predecessor, the Faculty of Comparative Culture, which consisted of two departments, the Department of Comparative Culture and the Department of Japanese Language & Studies.

The mission of the FLA and its Department of Liberal Arts is to prepare students of diverse backgrounds to take the lead in bridging differences and promoting understanding in the complex world of the twenty-first century. Through its broad interdisciplinary curriculum, centered on courses in the humanities, economics and business, and the social sciences, the faculty seeks to enlarge students’ general knowledge, to help them to develop critical thinking, and to nurture a broad, humanistic vision. All courses are conducted in English, and Core courses in English composition and public speaking equip students of different linguistic backgrounds to perform at a high academic level. Students are also strongly encouraged to study Japanese. The Sophia University Center for Language Education and Research (CLER) offers a variety of Japanese-language courses, from basic levels through to advanced courses, adapted to the needs of FLA students who enter with various levels of Japanese ability. Courses on Japan distributed throughout the curriculum enable students to understand both present-day Japan and its traditions in a global context.

Graduates of the faculty will receive a Bachelor of Arts degree, 学士(国際教養), accredited by the Ministry of Education, Culture, Sports, Science and Technology (MEXT).

## SECTION A: REGULATIONS AND PROCEDURES

### § a100 GENERAL INFORMATION FOR FLA STUDENTS

#### § a110 The Academic Year

The Faculty of Liberal Arts follows the same calendar as the other faculties of the university. There are two semesters, beginning in April and September. Each semester consists of 15 weeks of classes, followed by a final examination week.

#### § a120 Categories of Students

##### § a121 Degree Students

Degree students are those who intend to graduate from Sophia University. Degree students are admitted in both spring and autumn semesters.

##### § a122 Non-Degree Students

Non-degree students are those who enroll for a year to take courses and obtain credits but do not intend to earn an academic degree from Sophia University. This status is applicable only to international students who enroll as full-time students. Non-degree students are admitted in both spring and autumn semesters.

#### Requirements for Maintaining Non-Degree Status

A non-degree student must register for the equivalent of at least 10 hours of instruction per week. If the student does not register for a sufficient number of courses or fails to meet the deadline for the payment of tuition and fees, he/she will lose his/her student status at the university.

#### Change of Student Status

It is impossible for a non-degree student to change his/her status to that of a degree student without reapplying for admission as a degree student.

##### § a123 Non-Matriculated Students (科目等履修生自由履修コース)

Non-matriculated students are persons of any nationality who wish to take one or more courses of their choice, up to 30 credits in one year, but do not intend to earn a degree from Sophia University. In order to be eligible for this status, the student must hold a valid visa for Japan.

##### § a130 Loyola Web-service

The Loyola Web-service (Loyola) is the official academic web portal of Sophia University. Loyola brings together on one website important information and services related to academic matters.



Using Loyola students will be able to:

- Search course schedules and classrooms
- Register and withdraw from courses
- Check their registration status and grades
- Check information concerning cancelled classes, make-up classes, or notices on the Loyola web Bulletin Board
- Update registered personal data if there are any changes in the student's or guarantor's address
- Check and submit report assignments

Please refer to the "Loyola Handbook" (available online via Loyola) for detailed explanations on how to use Loyola.

#### **§ a140 Textbooks**

The textbooks and/or reference books necessary for classes will be listed on Loyola under "Curriculum Course Registration Info→Syllabus Inquiry". At the start of the semester, these books are available through the Kinokuniya website. For details, please see the Loyola Bulletin Board (Academic Services). If you are not required to have textbooks and/or reference books prepared before classes start, follow the instructions of the teacher on the first day of class.

#### **§ a150 Absence from Class**

Sophia University does not have a system for authorized absence from class or making notice of pre-approved absence. The Center for Academic Affairs cannot relay your message of absence. If you were absent from class due to unavoidable reasons such as bereavement, delay in public transport service, illness, extracurricular activities, or job searching, you need to see your class teacher in person and explain the situation (refer also to § a560). However, if you are absent during the Final Exams period, you may be allowed to take a make-up exam (§ a450).

If you need to be absent for a long period of time due to illness or injury, consult the Department Chairperson or your Area Coordinator.

---

## § a200 DEGREE REQUIREMENTS

### § a210 Credit Requirements

The Bachelor of Arts degree is awarded to students who successfully complete the required number of credits according to the distribution specified in the Bulletin of Information for the year in which they were admitted.

A study of 45 hours is required to earn one credit (based on government requirements of Standards for Establishment of Universities and Article 22 of Sophia University Regulations).

### § a220 Residence Requirements

Residence requirements refer to the amount of time a student must be enrolled in the university. With the exception of students who qualify for early graduation, a student must be enrolled for a total of four years (eight semesters) in order to graduate. The time spent on leave of absence or suspension from the university will not be counted as part of the residence requirement.

A student's total period of residence at the university may not exceed eight years, excluding the period of time spent on leave of absence from the university.

### § a230 Area and Major

#### § a231 Deciding One's Area

Students accepted into the Faculty of Liberal Arts as freshmen will choose, at the end of the first semester of their sophomore year, a major within one of three areas (Comparative Culture, International Business and Economics, or Social Studies). In the case of Comparative Culture and Social Studies, students must also select a primary and secondary field within the area. Students are also urged at this time to decide which language is to be counted for the general language requirement.

During the first semester of the second year, students will be notified about the procedures for making the choices mentioned above. Guidance for choosing a major (Sophomore Guidance) will be held every semester. For dates, see the Calendar for the academic year 2017. Students admitted to the FLA as transfer students at the junior level must indicate their intended major, fields, and language at the time of entry.

Note: The Chair of the Department of Liberal Arts is responsible for matters concerning freshmen and first-term sophomores. The Area Coordinators oversee matters concerning students who have declared an area and major.

#### § a232 Change of Major

In order to change majors, students must first consult the Area Coordinator of the major they want to transfer to.

### § a240 Certificates in Japanese Studies and Japanese Language Pedagogy

In addition to their major, FLA students who entered before 2015 may also obtain a certificate in Japanese Studies (日本研究履修証明) or a Certificate in Japanese Language Pedagogy (日本語教授法履修証明). For specifics, see § c200.

### § a250 Preparation for Graduation

It is the student's responsibility to make sure that he/she has fulfilled all the requirements for graduation. To check their progress toward meeting graduation requirements, FLA students should regularly use the Loyola online self-evaluation function. Any problems arising from the self-evaluation must be resolved with the Center for Academic Affairs before registration in a student's last semester. Refer to the online handbook concerning details for the self-evaluation function.

### § a260 Early Graduation

To qualify for early graduation, a student must complete at least three years (six semesters) of study, complete all credits required for graduation, and have a cumulative GPA of 3.50 or above. The FLA faculty will review applications for early graduation and decide which will be forwarded to the President of the University for approval.

*Application procedure:*

1. If a student wants to graduate after completing six or seven semesters of study, he/she should submit an application form to the FLA office by the application deadline as follows:  
Students who seek to graduate in September 2017:  
April 14 (Fri)  
Students who seek to graduate in March 2018:  
October 5 (Thu)
2. The applicant must be able to complete the remaining credits required for graduation within the term following application for early graduation. Please note that the remaining maximum number of credits for which an upper-class student may register is 24 credits per semester. Thus, students who wish to apply for early graduation at the end of the autumn semester must have no more than 24 credits remaining. For those who want to apply for early graduation at the end of the spring semester, the maximum number of outstanding credits permitted is 30 (24 for spring semester and 6 for the summer session).
3. The student must already have a GPA of 3.50 at the time of application.
4. Transfer students are not eligible for early graduation.
5. If a student wants to withdraw the request, he/she must notify the Chair of the FLA during the withdrawal period.

---

**§ a270 Transfer of Credits and Residency**

Students who have studied at other universities before entering Sophia University may be eligible for transfer credits and residency time. There are two categories for transferring credits and residency.

**§ a271 Transfer of Credits Earned before Entering as a Freshman:**

Up to 30 credits may be transferred. Students using this system may transfer credits, but not residency. However, students who meet all of the other qualifications may apply for early graduation (see § a260).

**§ a272 Transfer of Credits and Residency for Students Admitted as Transfer Students:**

The number of credits to be transferred may not exceed half of the required number of credits for graduation. Decisions about the transfer of credits will be made after consultation with the student's Area Coordinator. As a general rule, a transfer student must have completed at least two years of university/college work as a regular student at another institution before entering Sophia. A transfer student may transfer a two-year period of time in residence at his/her previous university/college. Acceptance as a third year student does not necessarily mean that you will automatically graduate in two years.

**§ a273 Application for Transfer of Credits:**

Students should apply for transfer of credits within three months of entering Sophia University. To apply, students should bring the following documents from their previous university/college:

- (1) official transcript (in English)
- (2) grading system explanation
- (3) academic calendar
- (4) syllabus of each course, containing a brief course description and course schedule

For (3) and (4), the description must be for the year that you registered for the courses.

## § a300 COURSE REGISTRATION

### § a310 Course Registration Procedure and Schedule (SPRING & AUTUMN 2017)

Event		SPRING	AUTUMN
1. Individual Advising		April 7 (Fri), 10:30 - 12:00	September 26 (Tue), 10:30 - 12:00
2. Course Registration		Sophomores, Juniors & Seniors: April 2 (Sun), 10:00 - April 12 (Wed), 21:00  Freshmen, Exchange & Non-degree: April 3 (Mon), 10:00 - April 12 (Wed), 21:00	Sophomores, Juniors & Seniors September 21 (Thu), 10:00 - September 30 (Sat), 21:00  Freshmen, Exchange & Non-degree: September 22 (Fri), 10:00 - September 30 (Sat), 21:00
3. First Lottery Registration	Period	Sophomores, Juniors & Seniors: April 2 (Sun), 10:00 - April 7 (Fri), 15:00  Freshmen, Exchange & Non-degree: April 3 (Mon), 10:00 - April 7 (Fri), 15:00	Sophomores, Juniors & Seniors: September 21 (Thu), 10:00 - September 25 (Mon), 15:00  Freshmen, Exchange & Non-degree: September 22 (Fri), 10:00 - September 25 (Mon), 15:00
	Registration Results Available Online	April 8 (Sat), 13:00	September 26 (Tue), 13:00
4. Second Lottery Registration	Period	April 8 (Sat), 13:00 - April 9 (Sun), 15:00	September 26 (Tue), 13:00 - September 27 (Wed), 15:00
	Registration Results Available Online	April 10 (Mon), 13:00	September 28 (Thu), 13:00
5. Final Lottery Registration (first-come-first-served basis)		April 10 (Mon), 13:00- April 12 (Wed), 21:00	September 28 (Thu) 13:00- September 30 (Sat) 21:00
6. Beginning of Classes		April 12 (Wed)	September 27 (Wed)
7. Result of Course Registration Available Online		April 13 (Thu)	October 1 (Sun) - October 2 (Mon)
8. Course Adjustment Period		April 14 (Fri), 10:00 - April 16 (Sun), 21:00	October 3 (Tue), 10:00 - October 5 (Thu), 21:00
9. Final Confirmation of Course Registration Available Online		April 18 (Tue), 13:00	October 9 (Mon), 13:00 -
10. Cancellation Period		April 19 (Wed) - 21 (Fri) 17:00	October 10 (Tue) - 12 (Thu), 17:00
11. Withdrawal Period		June 5 (Mon), 10:00 - June 9 (Fri), 18:00	December 4 (Mon), 10:00 - December 8 (Fri), 18:00

---

**§ a311 Course Information / Registration Materials**

After the designated distribution period, the following materials will be available at the Center for Academic Affairs:

- FLA Bulletin of Information
- Sophia University Academic Handbook (履修要覧), available only in Japanese and, on request, for students registering for courses offered by other faculties and programs at Sophia University.

The following material is available at the FLA office in Bldg. No. 10:

FLA Academic Record Sheet (for keeping track of credit requirements).

**§ a312 Individual Advising**

Individual advising will be offered by the FLA at the beginning of each semester. All students are urged to see an advisor. Freshmen and first-term sophomores should consult the Freshman Advisor assigned to them when they entered the university. Students who have declared their major should consult the Area Coordinator. The dates for the advising sessions will be posted on the Loyola Bulletin Board.

When consulting their Advisor or Area Coordinator about their individual programs, students should bring their transcript and academic record sheet.

**§ a313 Limit on Number of Credits per Semester**

Freshmen may register for a maximum of 20 credits per semester. Sophomores and above may register for a maximum of 24 credits per semester. These upper limits include courses taken in other faculties and programs. Registration for more than 24 credits (or 20 credits in the case of freshmen) is generally not allowed, but junior and senior students seeking certification as junior high school or high school teachers or as curators may register for additional credits as required for certification. They should consult the Center for Teaching and Curator Credentials. If students want to register for additional credits for other reasons, they should consult the FLA office.

**§ a314 Course Conflict**

A student may not register for two courses scheduled for the same day and hour. Students may not attend courses for which they have not officially registered.

**§ a320 Course Registration Period**

Students may register online (Loyola) for FLA courses and courses offered by other faculties and programs during the course registration period. During the course registration period, adjustments (add/delete) can be made any number of times except for lottery courses.

**§ a321 Course Registration Online** (URL: <https://scs.cl.sophia.ac.jp/campusweb/>)**【Note】**

-Unless an exception is specified, you cannot register for the same course you have already received credits for. The same courses are, generally, courses that have the same course code. If you need to register for a course which has the same code, please inquire at the Center for Academic Affairs.

-For courses offered by other faculties and programs, refer to the 2017 Academic Handbook (2017年度履修要覧).

-For online course registration, you must complete registration by the closing time on the last day of the Course Registration Period. Registration is finalized only when you click the "complete registration" (登録完了) button on the Course Registration screen. Note carefully that your registration will not be finalized unless you click on the button (登録完了) before the closing time. Also note that heavy access is expected on the last day of the registration period. Try to finalize your registration by the day before the closing date.

**§ a330 Lottery Courses**

Lottery courses are courses with limited class capacity, which include Studies in Christian Humanism, Information Literacy (compulsory for students who entered before 2011), Advanced General Education Courses and courses which are held in computer rooms and CALL rooms. The class capacity is indicated in the Remarks column on the course list. To take lottery courses, students must register during the lottery course registration period of each semester. The lottery is conducted by computer and only students selected in the lottery are registered for the course. The lottery courses, with some exceptions, that are successfully registered may be cancelled during the course registration period and course adjustment period. For details, see Loyola Bulletin Board/Academic Services.

**§ a340 FLA Core Program Courses**

Students who are scheduled to take FLA Core Program courses are assigned to class sections at the beginning of each semester. These assignments cannot be changed; students must register for the sections to which they have been assigned.

Students must enroll in the FLA Core Program courses in sequence. If a student fails a Core Program course, he/she must repeat and pass that course before proceeding to the next level. Neither cancellation nor withdrawal is allowed from FLA Core Program courses.

For details see § a364 and § a365.

**§ a350 Courses Offered by Other Faculties and Programs**

In addition to FLA courses, students may take courses offered by other faculties and programs as part of their graduation requirement. Except for compulsory courses such as "Studies in Christian

Humanism,” “Wellness, the Body and Culture” and some language courses (French, Spanish, Chinese and Japanese), most of the courses are conducted in Japanese. To register for courses offered in Japanese, a student must be a graduate of a Japanese high school or have demonstrated sufficient proficiency in Japanese by receiving a qualifying score on the Japanese Placement Test or by passing JPN343, Reading and Writing 3.

### **Types of Courses Offered by Other Faculties and Programs**

#### **§ a351 University-wide General Studies Courses 全学共通科目(Zengaku kyōtsū kamoku)**

- University-wide General Studies Courses not offered by the FLA.  
These courses can be counted as General Studies electives only. The courses are listed in the 2017 Academic Handbook (2017 年度履修要覧).
- Faculty-wide General Studies Courses 学全科目(Gakuzen kamoku)  
These courses not offered by the FLA may be counted as General Studies electives and Specialized Education electives courses, up to 16 credits. The courses are listed in the 2017 Academic Handbook (2017 年度履修要覧).

#### **§ a352 Language Courses**

- Japanese language courses.
- Language courses for FLA students (conducted in English).
- Language courses (conducted in Japanese).

#### **§ a353 Other Faculties’ Specialized Education Courses**

If a student takes these courses as Specialized Education elective courses, up to 16 credits can be included. Check the course syllabus to see whether those courses are open to FLA students.

#### **§ a360 Results of Course Registration**

Results of course registration will be available via Loyola. Please make sure to confirm the results and to prepare for course adjustment, if necessary.

#### **§ a361 Self-Evaluation and Category Changes on Loyola**

Students must check their own accumulated credits and adjust the category of courses via Loyola. Seniors should confirm that their self-evaluation is accurate, especially taking care that the category into which each course is placed will enable them to fulfill the requirements for graduation.

#### **■ “Self-Evaluation” Function**

This function enables students to check the courses completed and the credits earned for each category of graduation requirement. Students can use this function to calculate the number of credits still required for graduation based on the sum total of credits for current courses and the



credits earned so far.

■ **Self-evaluation Function Availability Period**

The Self Evaluation function on Loyola is available for a designated period only. For the schedule of available periods during the 2017 Academic Year, check the Loyola Bulletin Board (Academic Services).

■ **“Change of Category” Function**

The Change of Category function allows students to change the category of courses to meet their graduation requirements.

**In recent years, there have been cases of students who do not realize until just before they expect to graduate that they are not eligible to graduate due to errors in calculating the credits required and credits taken.**

To avoid such misunderstanding, students should use the Self-evaluation and Change of Category functions, as well as the Bulletin of Information, as students themselves are responsible for keeping track of their credits.

§ **a362 Course Adjustment**

Students can change or add courses (except lottery courses) any number of times during this period. As this is the final chance to register for courses, be careful.

§ **a363 Final Confirmation of Course Registration**

Final confirmation of course registration will be available online. Please make sure that you check the registration on Loyola carefully. It is the student’s responsibility to confirm that his/her registration is correct.

---

**§ a364 Cancellation Period**

If there are any errors in a student's course registration, he/she should apply for cancellation of course(s) before the end of the cancellation period. Students are allowed to cancel with approval from the Chair. Note that only cancellations are allowed. **Under no circumstances may courses be added at this stage.**

**§ a365 Withdrawal from Courses**

If a student decides after the cancellation period not to finish a course for which he/she has registered, the student should apply to withdraw from the course online (through Loyola). A "W" means that the student has asked for and obtained permission to withdraw from a course. This mark will remain permanently on the student's record, but will not appear on the student's official transcript. Please note that students will be responsible for full payment of the tuition charged for such courses. If a student discontinues attending a course and does not complete withdrawal online during the withdrawal period, he/she will receive an "F" for the course. The grade of "W" will not be calculated into the student's GPA, but an "F" will remain on the record. Students may not withdraw from compulsory courses in Health and Physical Education and Information Literacy (if taken as a GS compulsory course), from compulsory courses in the English Skills/FLA Core Program, and from language courses. For regulations on withdrawal from language courses, see the 'LANGUAGES' section of the FLA curriculum.

## § a400 EXAMINATIONS

### § a410 Types of Examinations

Examinations are held during or at the end of term in spring and autumn semesters, and are categorized into the following types:

Type of exam	Exam period / deadline of submission	Announcements of exam schedule, etc.	Make-up exam	Notes
In-class Examinations	Any time during class sessions (usually on the last day of class)	Given in class by the class teacher	Not applicable	Foreign language courses usually have in-class exams
Final Examinations (written tests)	During Final Exam period	Announced on Loyola by the Center for Academic Affairs	Applicable	
Final Papers	Report examinations / To be submitted by the deadline set at end of the term		—	General information is announced on Loyola Bulletin Board; note that the class teacher may give additional instructions in class.

### § a420 Final Examination Schedule

The final examination schedule will be announced on the Loyola Bulletin Board each semester two weeks before the first day of final examinations. Students are responsible for noting accurately the dates, the times and the classrooms of the examinations for the courses in which they are enrolled. Final exams in the FLA are generally 90 minutes in length.

### § a430 Examination Policy

Note the following policies concerning examinations:

1. The student must take the examination in the prescribed classroom.
2. The student's ID card must be placed on the desk during the examination.
3. If a student forgets his/her ID, he/she must obtain a Temporary ID Card (Fees: 500 yen) from the automatic certificate issuing machine on the 4th floor in Building 2. The Temporary ID Card is valid only for the day of issuance.
4. Students who come to the classroom more than 20 minutes after the beginning of the examination will not be allowed to enter under any circumstances. Also, no student may leave the classroom until 30 minutes after the beginning of the examination.
5. No student may leave the classroom unless he/she has submitted his/her answer sheet.
6. Mobile phones and wearable devices must be turned off and kept in the student's bag. They are not to be used for any reason during the exam.

7. As a rule, students are given only one answer sheet. If a student needs another answer sheet, he/she must return the first answer sheet.
8. If a student wishes to use an underlay pad for writing, it must be completely white or almost so. Using a notebook or other book as an underlay is not permitted.
9. A student's answers will become invalid under the following circumstances:
  - a. When there is no name or no ID number written on the answer sheet.
  - b. When any paper is submitted to the proctor other than the answer sheet handed out.
10. A student may be ordered to leave the classroom and have his/her answers invalidated under the following circumstances:
  - a. When a student continues to talk unnecessarily or exhibits improper behavior even after being warned.
  - b. When a student does not immediately follow the proctor's instructions.

#### **§ a440 Academic Dishonesty**

It is expected that all students will follow the highest standards of academic honesty.

#### **§ a441 Cheating**

If a student is found cheating in an exam or violating an exam policy/rule, Sophia University will impose severe punishment. Honesty is also expected at in-class exams held during class sessions. The following are some actions that are considered cheating:

- Using materials that are not permitted.
- Exchanging answer sheets with other students.
- Bringing in answer sheets written prior to the exam.
- Taking the exam for another student or having another student take the exam for you.
- Using mobile phones, wearables or other communication devices (you may not use them even as a watch to check the time).
- Other actions that violate the rules for administering exams.

The consequences of cheating are as follows:

- The student will be suspended or dismissed from the university, depending on the seriousness of the offense.
- The grade "F" will be entered on the student's record for the course.
- The student's grades for all other courses that have final written examinations during the final exam period will also become "F".
- Notice will be posted on the Campus Bulletin Board regarding the student who was found cheating.
- The suspended period will not be counted in the residence requirement and graduation will be delayed.
- Any scholarship the student is receiving from the university will also be canceled.
- The student's qualification for study-abroad, overseas short-term language/Study Abroad program, and nominations to university-organized programs may be canceled.

**§ a442 Plagiarism**

Plagiarism is defined as the use of the words or ideas of others, whether unintentional or deliberate, without proper acknowledgment. FLA instructors provide clear explanations about plagiarism in their course syllabi. Students are expected to read carefully each instructor's policy regarding plagiarism. Students must be aware that sanctions for plagiarism may vary depending on the discipline or the level of the course. Students have access to the syllabus of a course on the Loyola web-service. Furthermore, a copy of the syllabus is distributed to students during the first class at the beginning of the semester. If you plagiarize, you will be punished according to what is explained in the syllabus. When students are unsure whether or not a particular behavior might constitute an act of plagiarism, they should seek clarification from the course instructor.

**§ a450 Make-up Exams**

If a student is unable to take a final exam for one of the reasons specified, they may be allowed to take a make-up exam by submitting an "Application for Make-up Exams". This application must be submitted during the given period, and the student will need to obtain permission and pay a make-up exam fee.

No application for a make-up examination for courses that hold in-class exams (other than during the Final Exams period) is accepted.

**§ a451 Legitimate Reasons for Applying for Make-up Exams**

Legitimate reasons include illness, bereavement involving someone with a third degree of kinship, disasters, delay in public transport service, and appointment to lay judge service. The application procedure must be completed within the specified period, and the application for Make-up Exams must be accompanied by the following supporting documents to prove that the student was unable to come on the day of the final exam(s).

**§ a452 Supporting Documents and Procedures**

When applying for a make-up exam, bring the necessary supporting document (see below) and a print-out of the Loyola final exam inquiry screen.

1. Illness	Medical certificate or permission to return to school issued by a physician. *Payment receipts from a clinic are not acceptable.
------------	---

The medical certificate must state all of the following:

- a) The name of the illness and a statement by the physician attesting that the student was not in a condition to take an exam on the day of the exam.
- b) A statement attesting that the student was unable to come to the exam because of a scheduled consultation or because the student was undergoing treatment.

If the student had to be absent over several days, the medical certificate must clearly show that these days include the consultation day or the treatment period.

If the medical certificate does not state both a) and b), it will be deemed incomplete and the student will not be able to apply for a make-up exam.

\*In case of an infectious disease, application for the make-up exam(s) must also be filed during the designated application period for the make-up exams. If a student is unable to come to campus due to the infectious disease, he/she should contact the Center for Academic Affairs by telephone before the end of the application period.

2. Bereavement involving a third degree of kinship	Funeral service card/thank you card, etc. addressed to funeral guests.
--	--

The cards must show the date of the exam the student was unable to take.

※ Travel days will not be applicable to make-up exams.

3. Delay in public transport service	Delay certificates issued by the public transport service (indicating the date and the delayed time); a delay certificate printed out from the Internet is also acceptable.
--------------------------------------	---

If the delay in public transport service was 20 minutes or more and a student arrived at the exam more than 20 minutes past the scheduled starting time, he/she may apply for a make-up exam. However, the application must be filed on the very day of the delay in public transport service.

Note: An application for make-up exams due to the transportation delay will not be accepted on the day following the exam day or later.

NB:

\*If a student is unable to come to the university on the day of the delay for unavoidable reasons such as a shutdown of public transportation services or a long-distance commute, a “tentative application” must be made by telephone to the Center for Academic Affairs before 17:00 on the day of the delay (for exams held in the 5-6th class periods, them before the end of the exam time). If the student fails to file the “tentative application” during the above period, or if a proper application is not made following the “tentative application” during the specified period, he/she will not be allowed to apply for a make-up exam whatever the reasons may be.

\*The delay will be accepted only on a student’s normal commuting route between his/her home and the university. The Center for Academic Affairs will check the address given on the “enrollment sticker” on the back of the Student ID Card before accepting the application for the make-up exam.

\*The delay certificate must show a delay longer than the actual length of the student’s delay (e.g. the delay certificate must prove a delay of more than 30 minutes). Application for a make-up exam will not be accepted if the student did not make an effort to arrive on time for the exam.

\*A proxy application submitted by someone other than the student himself/herself will not be accepted for reasons of a delay in public transportation services.

If a student arrives late for the exam because of a delay in public transportation services, the student should take one of the following steps depending on the length of the delay:

(1) If a student arrives within 20 minutes of the scheduled exam starting time, he/she is allowed to take the exam. In such cases, the student should go directly to the classroom and take the exam.

(2) If a student arrives more than 20 minutes after the starting of the scheduled exam, he/she should immediately bring the delay certificate to the Center for Academic Affairs (Academic Services) on the 1st floor of Bldg. No.2., have the arrival time checked, submit the delay certificate and then apply for a make-up exam.

If the student is not sure where to go, he/she should go first to the exam room and follow the instructions of the exam supervisor.

If the reason for applying for a make-up exam is a natural disaster, selection for lay judge service, or some other reason, please inquire at the Center for Academic Affairs for more information on the application procedures.

**§ a453 Make-up Exam Fee: 2,000 yen per course**

**§ a454 Make-up Exam Schedule**

A make-up exam schedule will be announced on the Loyola Bulletin Board on behalf of the Center for Academic Affairs (Academic Services).

## § a500 GRADES

### § a510 Grading

A student's work is graded according to the following table:

Grade	Scale		Quality Point Index
A	100-90	Excellent	4.0
B	89-80	Good	3.0
C	79-70	Satisfactory	2.0
D	69-60	Passing	1.0
W		Withdrawal	
F		Failure	

The following "Grading Guideline" has been implemented by the university from the academic year 2015. The grades should be determined according to this guideline.

#### 【The Grading Guideline】

An "A" should be given to approximately 20% and no more than 30% of the registered students. This policy, however, does not apply to seminars, guidance courses, and lecture courses with registered students of 30 or less.

Although each course should be graded according to the evaluation criteria indicated in the course syllabus, professors should apply a grading curve to limit the number of A's to no more than 30% of the students in the course. As a result, when more than 30% of the students receive a raw score of 90 points (out of 100), those students outside the top 30% would receive a lower grade for the course.

### § a520 Grade Point Average (GPA)

Each grade is assigned a weight called the quality point index (QPI: e.g., A=4.0). The QPI multiplied by the number of credits for the course determines the quality points (QP) for that course. The sum of all the quality points divided by the total number of credits attempted (including the credits of a course for which an "F" is assigned) gives the grade point average (GPA).

N.B.

Grades received for courses offered by other faculties and programs will also be calculated into the student's GPA.



**§ a530 Grade Review**

Students must confirm their grades via Loyola at the end of the semester. If a student believes there has been a mistake in the grades, he/she may submit a request for grade review to the Center for Academic Affairs within office hours. Note that the purpose of this procedure is to confirm the accuracy of the grade recorded, not to petition for changing a grade. Final authority regarding grades rests with the instructor. No requests for grade review can be accepted after the deadline for submitting such requests.

*Deadline for Grade Review:*

*2017 Spring courses: September 20 (Wed), 2017*

*For Seniors and graduating students: August 28 (Mon)-August 29 (Tue), 2017*

*2017 Autumn courses: March 30 (Fri), 2018*

*For Seniors and graduating students: February 23(Fri)-February 27(Tue), 2018*

**§ a540 Repetition of a Course**

Unless otherwise specified, a student may not repeat for credit a course in which he/she has received a passing grade. If a student repeats the same course, the previous record will not be deleted from the transcript. This applies as well to courses being offered under a new name or number (see § b320, Change in Course Number and/or Title).

**§ a550 Honors**

The Dean's List is published each semester. To qualify, a student must be a degree student and have a semester average of 3.5 or better out of a possible 4.0, and must have completed at least 16 credits during the semester concerned.

**§ a560 Class Attendance at Classes**

Students are expected to attend all classes except in cases of illness (See § a980 "Infectious Diseases") or urgent necessity, for which written proof must be submitted to each instructor. Regardless of the excuse, absences do not exempt a student from quizzes, tests, examinations, or other written work required during the period of absence. The responsibility for making up such work rests wholly upon the student. A failing grade for missed or unsubmitted work will be assigned if the student does not fulfill his/her obligations within the time set by the instructor.

Look carefully at what is written on your syllabus about class attendance.

## § a600 CHANGE IN STUDENT STATUS

### § a610 Leave of Absence

A student who wishes to take a leave of absence must consult the Department Chairperson and submit a completed “Request for Leave of Absence” form (休学願). If the reason is illness, the form must be accompanied by a doctor’s certificate (診断書).

The period of leave of absence is not counted in the residence requirement and graduation will be delayed for the duration of the absence. A student who is taking a leave of absence cannot graduate in that term.

### § a611 Period of Leave of Absence

A leave of absence may be requested semester by semester. A leave of absence may not extend over two consecutive years or a total of 4 years (Article 32 University Regulations).

### § a612 Deadline to Submit Request

	Period of Leave of Absence	Deadline to submit request
Spring Semester	April 1 – September 20, 2017	May 31 (Wed), 2017
Autumn Semester	September 21, 2017 – March 31, 2018	November 30 (Thu), 2017

A student who intends to take a planned leave of absence must submit the “Request for Leave of Absence” at least one month prior to the beginning of the semester of the planned absence.

Any request submitted after the deadline will not be accepted for any reason. If the request is sent by postal mail, it must be postmarked on or before the deadline date. The request for leave of absence may be submitted for two consecutive years of absence.

### § a613 Tuition and Fees during Leave of Absence

There will be a reduction of the tuition and fees during a leave of absence. For more details, inquire at the Academic Records Section: Tuition and Fees, the Center for Academic Affairs.

### § a614 For Foreign Students with College Student Status of Residence

Students with a “College Student” Status of Residence who take a leave of absence may lose their status of residence in Japan. For details, please consult with the Academic Records Section.

**§ a615 Resuming Studies**

When the period for a leave of absence is over, student status returns automatically, so there is no need to submit an “Intent to Resume Studies” form (復学届). However, in the following cases, it is necessary to submit the “Intent to Resume Studies” form before the beginning of the semester.

- 1) Leave of absence due to illness (attach doctor’s certificate (診断書)).
- 2) A student wishes to return to studies earlier than scheduled: that is, when permission for the leave was obtained for 2 or more semesters but the student wishes to shorten the period of absence because the reason for taking the leave no longer exists (the period may not be shortened to less than one semester).

**§ a620 Suspension from the University**

A student who commits violations such as examination misconduct shall be given severe penalties including suspension or withdrawal from Sophia University according to Article 60 of University Regulations. The period of suspension is not counted in the residence requirement and such a student will not be able to graduate from university in four years, the normal residence requirement. The student will be able to return to university studies on the day following when the indefinite suspension is lifted or when the term of the definite suspension expires.

**§ a630 Withdrawal and Dismissal**

There are two types of withdrawal from university: voluntary withdrawal and dismissal.

**§ a631 Date of Withdrawal**

The date of withdrawal is the last day of the semester (September 20 or March 31).

**§ a632 Voluntary Withdrawal**

A student wishing to withdraw from university for certain reasons must consult the Department Chairperson, complete the "Request for Withdrawal from the University"(退学願) and submit the request to the Academic Records Section with the Student ID Card before the desired date of withdrawal.

**§ a633 Dismissal from the University**

The following students shall be dismissed from the university:

**1) Expiry of Period of Enrollment**

Students whose period of enrollment (excluding leave of absence period) exceeds 8 years.

**2) Students to Whom Article 40 of the University Regulations Applies**

Article 40: "Students who fail to obtain 32 credits or more including subjects specified by undergraduate departments in two consecutive academic years".

For students of the FLA, "two consecutive academic years" refers to four consecutive semesters excluding the period(s) of leave of absence.

For re-admitted students and second degree students, only the number of enrollment years and credits obtained after they re-entered or were admitted as second degree students will be calculated.

For transfer students, the number of enrollment years and transfer credits which were approved at transfer admission will be included in the calculation.

If a study abroad period exceeds one year, the period exceeding a year will be deemed a period

of leave of absence.

Credits obtained during study abroad approved within the consecutive two years will be included in the calculation.

The department individually contacts the students whose GPA is less than 0.5 and give guidance at the end of the academic year. This system is to give a chance to the students to look back their school life and study plan, and consult faculty staff on their future academic plan. In case the students do not show any improvement on their motivation after the guidance, the university may recommend withdrawal from the university.

**3) Failure to Pay Tuition Fees**

Students who fail to pay the tuition and fees before the set deadline.

**4) Other Reasons**

Students to whom Articles 60 and 61 of University Regulations apply.

**N.B. Preferential Measures**

Upon deliberation by the faculty and with an approval of the University President, a student who is in the third year or above, and who has taken less than 32 credits in four consecutive semesters excluding the period(s) of leave of absence, may be exempted from dismissal from the University by Article 40, if the total number of credits earned divided by the number of semesters of enrollment is more than 8 credits.

**§ a640 Change of Faculty/Department**

Students who wish to change to a department of another faculty and who satisfy the following requirements may do so by submitting the appropriate application form. After submitting the form, the student will take an exam given by the department.

**Eligibility**

- 1) The student has completed or is expected to complete at least four semesters of study at the time of the requested change (period of leave of absence is not included).
- 2) The student has a 2.6 GPA or higher for credits obtained in Language Courses (only Compulsory courses) and General Studies(全学共通). (Only General Studies for students who entered before 2014.)
- 3) The student satisfies all requirements set by the department he/she wishes to change to.
- 4) There is adequate reason for the change.

Note: Transfer of Faculty / Department is limited to one time.

Transfer students and Re-admitted students cannot apply.

Application to transfer to the Faculty of Global Studies is not possible.

**§ a650 Re-admission**

A degree student who has withdrawn or been dismissed from the university may re-enter the university upon approval of his/her application. However, if a re-admitted student withdraws or is dismissed a second time, or if the student was dismissed because his/her length of residence had reached the limit of eight years, he/she will not be allowed to apply for re-admission. Further information is available at the Academic Records Section.

**§ a660 Admission for a Second Degree**

Graduates of Sophia University may apply to enter another faculty or department. Further information is available at the Academic Records Section.

## § a700 STUDY ABROAD PROGRAMS

**§ a710 Exchange Program:** Students participating in this program are regarded as simultaneously enrolled at Sophia University and a foreign institution. Degree students who wish to study at an exchange partner institution are permitted to do so only if the Department Chair or Area Coordinator determines that such a choice would be educationally beneficial for the student. Internal screening will be conducted at Sophia University approximately one year before the beginning of the exchange period. The students must first pass the internal selection process to be nominated to the exchange program. Students studying abroad at a school with which Sophia University has a formal exchange agreement receive reciprocal treatment regarding credits and school expenses. For details, see “Handbook for Study Abroad” issued by the Center for Global Discovery.

**§ a711 General Study Abroad Program:** Students who plan to study abroad on their own and wish to transfer the credits back to Sophia University must apply in advance to the General Study Abroad Program. Credit transfer arrangements are the same as for Exchange Program students, but students must apply independently to an approved institution and arrange their own accommodation. Also, in contrast to the Exchange Program, students participating in the General Study Abroad Program must pay tuition and fees both to Sophia University and the overseas institution. For details, see “Handbook for Study Abroad.”

\* For both the Exchange Program and the General Study Abroad Program, students may study abroad for one year or one semester without taking a leave of absence.

**§ a712 Short-term Language Programs:** Sophia University sends students to several language programs at designated overseas universities during the summer and spring vacations. By participating in these programs and successfully completing the courses, students will be able to earn language credits that can be used for fulfilling Sophia University's graduation requirements.

**§ a713 Short-term Study Abroad Programs:** Sophia University sends students to several intensive programs on specialized subjects at designated overseas institutions during the summer and spring vacations. By participating in one of these programs and successfully completing the courses, students earn credits that can be transferred, with the approval of their department, as specialized education or general studies credits.

### **§ a714 Social Engagement Programs**

Sophia University sends students to several hands-on learning programs that include fieldwork and service learning during the semester or summer and spring vacations. By participating in one of these programs and successfully completing the courses, students earn credits that can be used for fulfilling Sophia University's graduation requirements.

## § a750 CERTIFICATION PROGRAMS

Pending completion of the required course work, FLA degree students may obtain certification in the following areas:

- Teacher Certification (教職課程/Kyōshoku katei)
- Curator Certification (学芸員課程/Gakugei-in katei)

These programs are taught only in Japanese.

Students interested in these programs should attend the special guidance meeting held by the Center for Teaching and Curator Credentials (notices will be posted on the Bulletin Board for Certification Programs). Information may be obtained at the Center for Teaching and Curator Credentials.

Credits in courses with course numbers (科目コード/Kamoku kōdo) starting with 62 taken by FLA degree students in the programs for Teacher Certification and Curator Certification may not be counted as fulfilling the credits required for graduation.

The tuition for the courses starting with 62 will be waived.

## § a800 TUITION AND FEES

### § a810 Tuition and Other Fees: Academic Year 2017

#### § a811 Degree Students

Currency : Japanese Yen

	Entrance Year				
	2017	2016	2015	2014	before 2013
Entrance Fee	200,000	—	—	—	—
Semester Enrollment Fee (per semester)	30,000	30,000	30,000	30,000	30,000
Tuition Fee per credit (1)	31,700	30,600	30,600	30,600	30,600
Education Enhancement Fee (per semester)	124,800 (2)	100,000	100,000	100,000	90,000
Alumni Association Fee (per year)	—(4)	5,000	5,000	5,000	—
Premium for Personal Accident Insurance for Students Pursuing Education and Research (3)	2,650	—	—	—	800

(1) Tuition fees are revised annually based on the rate of inflation.

(2) For students who enter in Spring 2017, the amount due for the Autumn semester is ¥105,000.

(3) If a student studies beyond the standard residence requirement, he/she will be charged ¥800 per year.

(4) The Alumni Association Fee (¥40,000) will be charged once in the final year.

#### § a812 Non-Degree Students

Currency : Japanese Yen

	Entrance Year	
	2017	2016
Tuition Fee (per credit)	33,600	33,600
Education Enhancement Fee (per semester)	105,000	105,000

**§ a820 Payment of Tuition and Fees****§ a821 Calculation of Tuition and Fees**

After final confirmation of course registration, a single adjusted bill will be issued, which will include all tuition and fees required for the term in question. For first-term students, the bill will include only tuition and the remaining fees that are not paid prior to entrance. Once registered for a course, a student is responsible for the payment unless he/she cancels the course during the Course Adjustment Period or Cancellation Period. Students are responsible for paying for any course from which they withdraw after the Cancellation Period.

**§ a822 Waived Tuition and Fees**

The tuition for courses listed below will be waived.

- Credits in course numbers starting with 62 (courses in the programs for certification as junior and high school teachers or for curators)
- Credits in course numbers starting with GCP (courses in the programs for Global Competency Programs)

**§ a823 Issuance of Bills**

*Dates when bills of tuition and fees are sent:*

*Spring 2017: May 2 (Tue), 2017*

*Autumn 2017: October 19 (Thu), 2017*

A bill and remittance form will be mailed to the student's address on the dates indicated above. Any student who does not receive the bill within one week after its issuance should notify the Center for Academic Affairs.

**§ a824 Deadline for Full Payment**

*Deadline for full payment of tuition and fees:*

*Spring 2017: May 16 (Tue), 2017*

*Autumn 2017: November 2 (Thu), 2017*

Failure to complete payment will result in dismissal from Sophia University.

Students who are experiencing financial difficulties should consult with the Center for Student Affairs for scholarship and other information.

**§ a825 Fees to be Paid During a Leave of Absence**

During a leave of absence, the following fees must be paid by the tuition payment deadline:

Semester Enrollment Fee, Education Enhancement Fee (only first-term students), Alumni Association Fee, Premium for Personal Accident Insurance for Students Pursuing Education and Research.



## § a900 ANNOUNCEMENTS FROM UNIVERSITY OFFICES

### § a910 Bulletin Boards

Notices concerning classes (cancelled classes, make-up classes, change of classrooms, and exam schedules) and announcements for individual students, including urgent matters, will be posted on the Loyola Bulletin Board. Some notices may also be posted on university bulletin boards (see § d300, Yotsuya Campus Bulletin Boards in Building No.2 1F for the location of the bulletin boards). All students are strongly advised to check the Loyola and university bulletin boards regularly.

### § a920 How to Contact Your Teachers

The class teachers are either full-time faculty of Sophia University or part-time lecturers from other universities coming to teach a particular course. If a student wishes to contact his/her teachers, the following are the ways depending on whether they are full-time or part-time:

#### 1. Full-time faculty:

Full time faculties have offices on campus and individual office hours for student appointments. If you need to make an appointment outside of office hours, contact your Department office for instructions.

Also, there is a class advisor for each undergraduate class or seminar. The student may seek advice on studies, course enrollment, career options and any difficulties in student life.

•List of teachers' offices and their office hours	: Academic Handbook 履修要覧/Bulletin of Information
•Department offices	: 履修要覧(listed first on pages of each Department)
•List of class advisors of Departments	: Academic Handbook 履修要覧/Bulletin of Information

#### 2. Part-time lecturers / Adjunct professors

Part-time lecturers / Adjunct professors do not have offices on campus; contact them before or after classes. Some teachers may release their personal e-mail addresses to students.

Information on whether or not a teacher releases his/her contact address, and if so, the address itself, is available at the Center for Academic Affairs (Academic Services). Students should bring their Student ID Card and inquire in person.

For protection of personal information, the Center for Academic Affairs does not accept telephone inquiries.

The Center for Academic Affairs does not relay messages from students to their teachers.

#### 3. If you do not know whether the teacher you wish to contact is a full-time or part-time teacher:

Please check the list of courses with names of class teachers (Academic Handbook 履修要覧) to see whether the teacher is full-time / part-time.

The teachers with an asterisk “\*” in front of their names are part-time lecturers; those without an asterisk are full-time faculty.

### § a930 Certificates

Various certificates can be obtained either from the certificate issuance machine or at relevant offices. Check the type of certificate you need and apply as follows:

#### Certificates from the Certificate Issuance Machine

Certificates	Fees	Day of issue	Notes
Certificate of Attendance (Japanese / English)	¥200	On the same day	Issuance machines are installed on: · 4th floor, Bldg. No.2; · Mejiro Seibo Campus (in office center)  Service Hours: Mon. - Fri. 9:00 to 17:00 *any changes due to school events will be announced
Official Transcript (Japanese / English)	¥200		
Certificate of Prospective Graduation (Japanese / English)	¥200		
Student Discount Certificate	free		
Medical Checkup Certificate (university designated form in Japanese only)	¥300		
Temporary Student ID Card (issued only during Final Exam period)	¥500		

Please follow the voice instructions of the certificate issuance machine on how to operate the machine.

- \* A student ID Card is required in order to have the certificate issued. The certificate issuance machine is available for current students only.
- \* The Certificate of Prospective Graduation certifies that the student is eligible to graduate if the student has met all graduation requirements, but it does not mean that Sophia University guarantees the student's graduation.
- \* Up to 10 copies of Student Discount Certificate can be issued from the machine. If you need more copies, please inquire at the Center for Student Affairs.
- \* For the password, inquire at the Center for Academic Affairs, Academic Records Section.

#### Certificates Issued at the Center for Academic Affairs

Certificates	Fees	Day of issue
Certificate of Prospective Acquisition of Teacher's License	¥400	Takes 3 working days from the application date
Certificates necessary for application of "Permission to change the status of residence" and "Permission to extend period of stay"	¥200	Application received → Day of issue · Mon./Tue. → Fri. · Wed./Thu. → following Mon. · Fri. → following Wed.
Re-issue of Student ID Card	¥1,000	On the same day

Office in charge: Center for Academic Affairs, Academic Records Section  
 1F, Bldg. No.2

Office hours: Mon. - Fri. 9:30 - 11:30, 12:30 - 17:00

\* Any changes due to school events will be announced on Loyola.

- 1) Complete the application form available at the Center for Academic Affairs.
- 2) Purchase the fee payment sticker from the vending machine and place it on the application form.
- 3) Submit the application form with your Student ID Card to the office. Receipts will be issued to the applicant.
- 4) On the day of issue, show the receipt at the office and receive the certificate.

#### **§ a940 Student Identification Card (ID Card)**

The Student ID Card certifies that you are a student of Sophia University. Carry it with you at all times as you may be asked to show it in various situations both on and off campus. Services may not be provided if you do not have your Student ID Card.

Student ID Cards should not be lent or given to another person whatever the reasons may be. Return the Student ID Card to the University when you lose your student status by withdrawal from Sophia University.

You will need the Student ID Card in the following cases:

- 1) to take exams
  - 2) to use the certificate issuance machine and obtain a certificate or student travel fare discount certificate
  - 3) to enter the university main library and to borrow library books
  - 4) to buy your commuting pass
  - 5) to show at the request of officials when you are on trains, etc. using a commuting pass or student discount ticket
  - 6) to submit various application forms at the office
  - 7) to show when requested by a faculty member or staff of Sophia University
1. Valid Enrollment Sticker  
The student ID Card is valid only with a current Enrollment Sticker (在籍確認シール) affixed on the back. The sticker is valid for one year; students should obtain a valid current sticker at the beginning of each academic year. Notify the Academic Records Section if there are any changes to your address or commuting route, or when there is no vacant column left in the commuting pass issue record.
  2. Changes in the Data of Student ID Card  
If there are any changes or errors in the data (name, date of birth, etc.) on the Student ID Card, notify the Academic Records Section.
  3. Lost, Damaged or Defective Student ID Card  
Request a re-issue of your card at the Academic Records Section, and then purchase a fee payment sticker (1,000 yen) and place it on the designated form, “Request for Re-issue of Student ID Card” (学生証再発行願).

### § a 950 Change of Address or Phone Number

When there are changes in students' or guarantors' address or phone number, students should update the information through "Address registration" menu on Loyola. In case the guarantor's address is outside Japan, students should submit the "Address change sheet (住所変更届)" to the Academic Records Section. This option is only for non-Japanese students. When students change their own address, they need to obtain a new enrollment sticker (在籍確認シール) at the Academic Records Section.

### § a 951 Change of Student's Name

If there is a change in student's name, submit a "Name change sheet (氏名変更届)" available at the Academic Records Section, and attach a Certificate of Residence (住民票の写し) issued by the local government stating the student's full name, gender, and date of birth. Permanent address, family relation information, and individual number (My Number) are not required.

### § a 952 Guarantor

Sophia university requires all students to have a guarantor. Sophia University sends important notices regarding academic affairs and school newsletters to the guarantor's address, or may contact the guarantor in the case of an emergency.

A guarantor should be one of the below (listed in order of priority):

1. A parent who lives in Japan
2. A person who lives in Japan and earns his/her living independently
3. A person who earns his/her living independently and who lives in a foreign country (this option is only for non-Japanese students).

### § a 953 Change of the Guarantor

If students intend to change the guarantor, they need to submit the "Guarantor change sheet (保証人変更届)" to the Academic Records Section.

### § a 954 Change of Nationality

If there is a change in student's nationality, submit a Certificate of Residence (住民票の写し) issued by the local government, which includes the full name, gender, date of birth for all students, and nationality, status of stay, period of stay and resident card number for non-Japanese students.

### § a 960 For Non-Japanese Students (Residence Status)

All non-Japanese students are required to notify their residence status and period of stay in Japan to Sophia University. When they renew the resident card, they should submit a photocopy of their resident card as soon as possible. Failure of submission may incur suspension of Loyola ID, termination of scholarship benefits, or other inconveniences.

**§ a 961 Residence Status of “College Student”**

Residence permission is the permission for non-Japanese residing legally in Japan for the mid- to long-term who have resident status under the Immigration Control Act (mid- to long-term residents). Students who study at a university in Japan may obtain “College Student” status. Non-Japanese students should carry their resident card at all times.

If students who hold college student status take a leave of absence or withdraw from the University, they should change their residence status or leave Japan.

**§ a 962 Extension of Period of Stay Under the “College Student” Residence Status**

When students holding “College Student” status intend to extend their period of stay, they should fill out the application for extension of period of stay “For applicant, part 1-3”. The “For organization, part 1-2” must be filled out by the Academic Records Section. The issuing fee is 200 yen and will take 3 working days.

Students can apply for an extension from 3 months prior to the expiration date at the Immigration Bureau. Please be aware that staying in Japan beyond the period of stay is illegal and may be punished.

**§ a 963 Change of Residence Status to “College Student”**

When students intend to change their residence status to “College Student”, they should fill out the application for change of status “For applicant, part 1-3”. The “For organization, part 1-2” must be filled out by the Academic Records Section. The issuing fee is 200 yen and will take 3 working days.

Register the changes in your status of residence at the residential municipal office within 14 days.

**§ a970 When Public Transport Service is Shut Down**

When the University decides that it is not possible to hold regular classes or final exams due to the shutdown of transport services caused by natural disasters such as typhoons, heavy rainfall, accidents or strikes, classes will be canceled and exams rescheduled to another day. Such cancellations and changes will be announced through the University's official website, Loyola or via the University's official Facebook and Twitter accounts. Be sure to check one of these sites.

**§ a980 Infectious Diseases**

When students contract an infectious disease as defined by the School Health and Safety Act, they are not allowed to come to school for a certain period of time to prevent the spread of the disease.

If students contract a new infectious disease such as a new strain of influenza, special measures may be taken; please check announcements on Loyola and the official University website.

Should you contract such a disease, take the following steps:

1. You must follow your physician's instructions and stay home until there is no risk of infection. Please notify the university Health Center of your situation by phone, fax (download the report form from the official University website) or Loyola.

2. Download the “Doctor’s permission to return to campus (Toko Kyoka Sho)” (感染症治癒後登校許可証明書) form from the official university website and have it filled out by your physician (a form from any medical organization may be used if it states the period the student is not allowed to go to school).
  - ※ If you cannot download the form, ask for the form at the Health Center.
3. When you return to school, submit the above original certificate to the University Health Center and photocopies of the certificate to each of your class teachers.

#### **§ a990 Absences Due to Lay Judge Service**

Based on the “Act on Criminal Trials Examined under the Lay Judge System,” students may decline to serve as lay judges under the lay judge system. However, in order to respect the wishes of students who consent to being appointed as lay judges, absences due to lay judge service (including any attendant procedures) will be treated as follows.

#### **§ a991 Scope of Policy**

This policy applies to degree-seeking undergraduate and graduate students as well as non-matriculated students. This policy does not apply to auditing students.

#### **§ a992 Accepted Grounds for Absence**

- a. Appearing at a courthouse as a lay judge candidate for appointment procedures.
- b. Attending a trial as a lay judge.
- c. Sitting in on trial proceedings as an alternate lay judge.

#### **§ a993 Procedures**

In general, students must contact the Center for Academic Affairs, receive a copy of the designated Notification of Absence due to Lay Judge Service form, and submit this form, along with a copy of the Notice of Date for Lay Judge Appointment sent in the mail from the court, to the faculty member(s) in charge of the class(es) from which the student is to be absent. The student must also show to the faculty member(s) the post-trial discharge certification documentation issued by the court.

#### **§ a994 Handling of Absences**

Provided that the student has given notice of absence by means of the designated forms mentioned above, faculty will observe the following considerations to avoid causing detriment to the student.

- a. Classes missed will not be counted as absences.
- b. For in-class exams, make-up opportunities will be determined by the faculty member.
- c. For the final exams held during the final exam week, the student may apply for a make-up exam. The student must follow the procedures for filing a make-up application, and submit the necessary documents by the deadline (see § a450 Make-up Exam for details).



## SECTION B: FLA CURRICULUM

### § b010 INFORMATION ON CURRICULUM

#### § b011 Course numbering

- 100-level courses:** Designed for beginning students. These include FLA Core courses, General Studies courses for beginning students, and beginning language courses.
- 200-level courses:** Introductory courses to the various disciplines; designed for first- and second-year students. Every academic discipline has its own language of analysis, and these courses are intended to introduce students to the basic analytical concepts and language of a specific field. Students should begin their study of a discipline with the 200-level course or courses in that field.
- 300-level courses:** Courses that concentrate on more specialized areas within a discipline, providing in-depth knowledge of a particular sub-field. These courses are designed for second- and third-year students.
- 400-level courses:** Advanced or specialized courses within a discipline; designed for third- and fourth-year students. A 400-level course will often require more independent research or an extensive research paper.
- Prerequisites:** Check the syllabus before registering for a course. Course syllabi are available on the Loyola web-service before the registration period. In the syllabus students will find clear information about prerequisites. Enforcer prerequisites will not allow a student to register for a course. Informer prerequisites will allow students to register for a course. If they do not meet the prerequisites, faculty members will ask students to cancel the course (except if faculty members have given them special permission). If students do not cancel (or withdraw), they may receive an F.

#### Course Codes

FIELD (Alphabet)	FIELD
ANT	Anthropology
ART	Art History/Visual Culture
COM	Computer Studies
ENG	English
ENV	Environmental Studies
GEO	Geography
HST	History
IBE	International Business and Economics
LIT	Literature
LNG	Linguistics
MTH	Mathematics
POL	Political Science
RPH	Religion/Philosophy
SOC	Sociology
THP	Thinking Processes



**§ b012 Pedagogical Philosophy**

The Faculty of Liberal Arts [FLA] provides an all-English liberal arts education in the fields of Comparative Culture, Social Studies, and International Business and Economics. While offering courses in such fields as well as cross-disciplinary courses, so as to allow a more organic, comprehensive understanding in the field, the FLA also aims to help students to achieve advanced language proficiency and intellectual criticality and flexibility in order to act as mediators between different cultures and countries. Through academic training and research, the FLA contributes to the understanding of current affairs in today's globalized world and also to the solving of the various social issues we face.

**§ b013 Educational Purpose**

The purpose of the FLA education is to nurture students' cosmopolitan outlook, their language ability, and flexibility in thinking in order to act as bridges between different cultures within the context of globalization.

**§ b014 Curriculum Policy**

While the FLA offers an all-English curriculum, guiding students to develop advanced communication skills in English, it also requires students to study a second language. Students who lack sufficient Japanese language ability are strongly encouraged to take Japanese as their second language.

In the Core Program, students are trained intensively to develop the ability to read and analyze texts, to present and discuss ideas in public, to write effectively in English, and to think logically and critically in an academic setting.

Toward the end of the sophomore year, students must choose one major among three areas: Comparative Culture, International Business and Economics, and Social Studies. Students are also encouraged to widen their academic scope and improve intellectual flexibility by taking courses from neighboring areas, while strengthening their knowledge in their major. By interacting with professors and students of various cultural backgrounds, FLA students learn to examine alternative perspectives and equip themselves with the communicative skills necessary to navigate and contribute productively to multicultural environments.

**§ b015 Diploma Policy**

A bachelor's degree is awarded to students who earn the required number of credits, which includes credits in required general studies courses and courses in the student's chosen major. Students are expected to acquire what the faculty calls "global competency," the goal of which is the capability of working in international environments while adhering to the university's principle of "men and women for others, with others." This global competency is dependent on the following three fundamental skills:

1. Advanced English language skill and fluency in other language(s).
2. Highly-developed communication skills in multicultural environments.
3. Intellectual ability to combine specialized knowledge with a broader vision in order to examine various solutions for a wide range of problems.

Note: The English translation is provided for information, and the Japanese version remains the sole official version. If there is any discrepancy between the two versions, the Japanese original should take precedence.

---

**§ b100 CURRICULUM FOR STUDENTS WHO ENTERED FROM 2014**

<b>GENERAL GUIDELINES</b>	<b>§ b101</b>
<b>UNIVERSITY-WIDE GENERAL STUDIES REQUIREMENTS</b>	<b>§ b110</b>
<b>Studies in Christian Humanism</b>	<b>§ b111</b>
<b>Health and Physical Education (HPE)</b>	<b>§ b112</b>
<b>General Studies Elective Subjects (GS)</b>	<b>§ b113</b>
<b>CATEGORIES AND LIST OF COURSES</b>	<b>§ b120</b>
<b>FLA Distribution Courses</b>	<b>§ b121</b>
<b>FLA General Courses</b>	<b>§ b122</b>
<b>Advanced General Education Courses</b>	<b>§ b123</b>
<b>LANGUAGE COURSES</b>	<b>§ b130</b>
<b>General Guidelines</b>	<b>§ b131</b>
<b>Course Registration for Japanese</b>	<b>§ b132</b>
<b>Course Registration for Chinese, French, and Spanish</b>	<b>§ b133</b>
<b>Course Registration for Other Languages</b>	<b>§ b134</b>
<b>Attendance Policy</b>	<b>§ b135</b>
<b>FACULTY-WIDE SPECIALIZED EDUCATION</b>	<b>§ b140</b>
<b>FLA Core Program Courses</b>	<b>§ b141</b>
<b>FLA Major Courses (General Guidelines)</b>	<b>§ b142</b>
<b>FLA-wide Specialized Education Electives (SE)</b>	<b>§ b143</b>
<b>FLA MAJOR COURSES</b>	<b>§ b150</b>
<b>FLA Comparative Culture Major</b>	<b>§ b151</b>
<b>FLA International Business and Economics Major</b>	<b>§ b152</b>
<b>FLA Social Studies Major</b>	<b>§ b153</b>
<b>SELF- EVALUATION</b>	<b>§ b160</b>

## § b101 GENERAL GUIDELINES

<b>TOTAL CREDITS REQUIRED FOR GRADUATION</b>	<b>124 credits</b>
--	--------------------

The Curriculum is divided into three parts:

UNIVERSITY-WIDE GENERAL STUDIES (GS)

(全学共通科目 /Zengaku Kyōtsū Kamoku/)

COMPULSORY LANGUAGE COURSES (LA)

(語学科目 /Gogaku Kamoku/)

FLA-WIDE SPECIALIZED EDUCATION (SE)

(学科科目 /Gakka Kamoku/)

<b>UNIVERSITY-WIDE GENERAL STUDIES (GS)</b>	<b>22 credits</b>
---	-------------------

### 1. Compulsory Elective Subject(選択必修科目 /Sentaku Hisshū Kamoku/)

Studies in Christian Humanism	4 credits
-------------------------------	-----------

### 2. Compulsory Subject (必修科目 /Hisshū Kamoku/)

Health and Physical Education	2 credits
-------------------------------	-----------

### 3. General Studies Electives Subjects (選択科目 /Sentaku Kamoku/)

FLA Distribution Courses	12 credits
--------------------------	------------

Advanced General Education Courses	2 credits
------------------------------------	-----------

FLA General Courses or University-wide General Courses	2 credits
--	-----------

<b>COMPULSORY LANGUAGE COURSES (LA)</b>	<b>8 credits</b>
---	------------------

Language Courses	8 credits
------------------	-----------

<b>FLA-WIDE SPECIALIZED EDUCATION (SE)</b>	<b>94 credits</b>
--	-------------------

### 1. Faculty of Liberal Arts Core Program (compulsory subjects)

English Composition 1	4 credits
-----------------------	-----------

English Composition 2	4 credits
-----------------------	-----------

Thinking Processes	4 credits
--------------------	-----------

Public Speaking	4 credits
-----------------	-----------

### 2. Faculty of Liberal Arts Major Courses (compulsory electives)

Major Courses	48 credits
---------------	------------

### 3. Faculty of Liberal Arts Specialized Education Electives

Specialized Education Electives (SE)	30 credits
--------------------------------------	------------

**§ b102 GENERAL GUIDELINES: Compulsory subject**

Compulsory courses must be taken by FLA students in order to meet the requirements of their program. Students are placed in a particular section of the course and cannot change that section. Usually, students cannot withdraw from these courses.

**§ b103 GENERAL GUIDELINES: Compulsory elective subject**

FLA students may select these courses from the list of compulsory courses included in the FLA Bulletin of Information.

**§ b104 GENERAL GUIDELINES: Elective subject**

FLA students can choose course from a wide range of courses in this category. Students must read the Bulletin of Information carefully before choosing these courses. Elective courses are divided into different categories and there are limits to the number of courses students can choose in each category in order to meet the requirements of the FLA program.

**§ b105 GENERAL GUIDELINES: Studies in Christian Humanism**

In order to better understand Sophia University's founding spirit, undergraduate students must fulfill a University-wide requirement by taking Studies in Christian Humanism (キリスト教人間学/Kirisuto Kyō Ningengaku/) courses. This is a compulsory subject FLA students must complete to meet the requirements of their program. FLA students must choose sections of the course offered in English.

More information about these courses can be found in paragraph b111, and detailed explanations can be found in the *Studies in Christian Humanism* brochure published by the Faculty of Theology. Course syllabi can be accessed through the Loyola web-service.

**§ b106 GENERAL GUIDELINES: Health and Physical Education (HPE)**

It can be challenging to balance the many aspects of daily living. Sophia University offers a compulsory course for all students to be taken during their first year to discuss topics such as health, sports, culture and society based on their bodily experiences. All FLA students will be assigned to a section of Wellness, the Body and Culture (ウェルネスと身体). This is a compulsory subject FLA students must complete to meet the requirements of their program. The course is offered in English or Japanese.

More information about the course can be found on the Loyola web-service.

**§ b107 GENERAL GUIDELINES: Advanced General Education Courses**

In 2013 the University decided to create a new course as part of the University-wide General Studies curriculum. The course Advanced General Studies (高学年向け教養科目/Kōgakunenmuke Kyōyō Kamoku/) must be taken after the fourth semester. This is a subject FLA students must complete to meet the requirements of their program.

More information about those courses can be found on the Loyola. See also § b113.

### **§b108 GENERAL GUIDELINES: FLA-wide undergraduate Academic Advising System**

The FLA Undergraduate Academic Advising System (GUIDE) was developed over the years to help students prepare for their first year of studies, develop plans for choosing a major, understand and complete graduation requirements and avoid administrative problems.

The FLA GUIDE system is a complement to other advising resources offered by Sophia University.

The FLA GUIDE system is divided into three stages:

- Freshmen-First-term sophomores. During that period the Chair of the Department of Liberal Arts and advisors are available to guide students. Important events such as the Orientation Camp and student advising sessions at the beginning of each semester are provided for student guidance.
- Sophomores choosing their majors. During that period the Dean, the Chair and Coordinators are available to guide students. Events such as information sessions for choosing a major and completing self-evaluations are provided to students.
- Final-term seniors. During that period the Dean can advise students.

### **§ b110 UNIVERSITY-WIDE GENERAL STUDIES REQUIREMENTS**

#### **§ b111 STUDIES IN CHRISTIAN HUMANISM (4 cr.)**

“Studies in Christian Humanism” courses are two credit courses. FLA students need to take two of these courses for a total of 4 credits to meet graduation requirements. Normally, students must take one course in their first semester and another in their second semester. Students placed in the “Academic English Skills” section of the Core Program are advised to start taking these courses during their second and third semesters.

- **Information about “Studies in Christian Humanism” courses:**

The “Studies in Christian Humanism” courses have been placed in five sections or blocks. FLA students can take only the courses in section E. Courses in section E are offered once a week on Tuesday during the fifth period. Information about the section E courses can be found in the “Studies in Christian Humanism” brochure published by the Theology Faculty or on Loyola. Questions about Christian Humanism courses can be directed to the Office of the Faculty of Theology in Bldg. No.7.

- **Cancellation or Withdrawal**

Cancellation and withdrawal periods are available for FLA students.

- **Registration for “Studies in Christian Humanism” courses:**

These courses are ‘lottery courses.’ Pay special attention to registration procedures. For information about lottery courses, check the ‘Course Registration Quick Navi’ brochure published by the Center for Academic Affairs or the “registration” section of the Loyola student handbook. At the beginning of the semester important announcements

about lottery courses will be posted on the Loyola Bulletin Board (Academic Services).

- List of Courses for FLA students:

Registration CD	Semester	Course Title	Credits
GSG19110	Spring	Philosophy of the Human Person	2
GSG18910	Spring	Philosophy of Human Rights and Human Dignity	2
GSG18920	Spring	Philosophy of Religious Language	2
GSG19510	Spring	Freedom and Leadership : Ignatian Spirituality for Life	2
GSG19740	Autumn	Philosophy of the Human Person	2
GSG18930	Autumn	Philosophy of Religious Language	2
GSG19370	Autumn	Philosophy of Human Nature	2
GSG19410	Autumn	Freedom and Leadership : Ignatian Spirituality for Life	2

### § b112 HEALTH AND PHYSICAL EDUCATION (HPE)

“Wellness, the Body and Culture” (2cr) is compulsory for all students entering from 2009. This course should be taken in the semester the student enters the university. The course will be offered in English and Japanese. Students will be assigned to the appropriate class. An adapted course for students with disabilities will be offered every spring semester.

Details about the course will be announced on the Loyola Bulletin Board (Academic Services).

Note that neither cancellation nor withdrawal is allowed for compulsory HPE courses.

- **Students entering in 2017** will be assigned to one of the class sections. The class assignment will be posted on Loyola. Students should check the Loyola web service bulletin board and be sure to register for the course they have been assigned to.
- All sections of “Wellness, the Body and Culture” are offered on Wednesday, 13:30 -15:00. However, the adapted course for students with disabilities during the spring semester will be offered on Friday, 11:00 – 12:30.
- Be sure to bring a photo (3 x 3 cm) and a pen to the first class session.
- **Students who entered before 2017 and transfer students** who have not yet completed “Wellness, the Body and Culture”, should come to the meeting room of HPE department (Bldg. No.7, 2F, 220) for registration on April 5 (Wed) 10:00~12:00 for Spring semester, or on September 20 (Wed) 10:00~12:00 for Autumn semester. Please note that registration is on a first-come-first-served basis and the number of acceptance is limited.

Class will be assigned and a permission sheet will be issued at the registration and it should be submitted to the Center for Academic Affairs during the period below.

< Submission period of permission sheet (During office hours) >

Spring semester : April 12 (Wed) – April 18 (Tue)

Autumn semester : September 27 (Wed) – October 3 (Tue)

### § b113 GENERAL STUDIES ELECTIVES SUBJECTS (GS)

All students in the Faculty of Liberal Arts must take 16 credits in total of GS Electives courses as part of the University-wide General Studies program.

- A minimum of **12 credits** from at least 2 of the 3 categories of FLA Distribution Courses (see § b121)
- A minimum of **2 credits** from the category “Advanced General Education Course” (see § b123)
- Of the remaining 2 credits, students may take courses from FLA General Courses (see § b122) or University-wide General Studies Courses (全学共通科目 /Zengaku Kyōtsū Kamoku/)

Notice that some courses are listed under both General Studies and Specialized Education categories and may be chosen to fulfill requirements in either category. However, the same course may not be used to fulfill requirements in both categories simultaneously.

### § b120 CATEGORIES AND LIST OF COURSES

#### § b121 FLA DISTRIBUTION COURSES

**Society and Culture:** The courses in this category introduce students to the experiences of different human societies, from ancient times to the present. They look at the development of institutional, intellectual, and social patterns that continue to influence our way of thinking and acting today.

HST251	Development of Japanese Civilization 1
HST252	Development of Japanese Civilization 2
HST261	History of Chinese Civilization
SOC201	Introduction to Sociology
SOC210	Introduction to Social Theory
SOC225	Introduction to Japanese Society
ANT202	Introduction to Cultural and Social Anthropology
ANT220	Anthropology of Japan
ANT230	Culture and Identity

**Cultural Traditions:** From the very beginning humans have sought to communicate their ideas about themselves, their societies, and the world. The courses in this category introduce written and artistic expressions of human creativity. They provide students with experience in the analysis and interpretation of particular literary texts, philosophical concepts, works of art, systems of belief and symbolic structures.

ART201	Introduction to Art History/Visual Culture 1
ART250	Introduction to Art History/Visual Culture 2
LIT201	Literary Genres
LIT231	Introduction to Japanese Literature
RPH201	Introduction to Philosophy
RPH202	Fundamentals of Religion
LNG210	Introduction to Linguistics

※LIT260 and 270 taken in 2015 may be counted for this category.

**Politics and Economy:** Political and economic factors play a major role in shaping the world in which we live. The courses in this category introduce students to some of the major approaches for investigating the nature and impact of such factors.

IBE200	Principles of Microeconomics
IBE201	Principles of Macroeconomics
POL201	Theories and Themes of Contemporary Politics
POL205	Introduction to International Relations
POL210	Introduction to Comparative Politics
POL215	Controversies in Globalization
MTH111	Mathematics and Statistics for Business and Economics

### § b122 FLA GENERAL COURSES

COM221	Computer Studies 1*
COM222	Computer Studies 2*
COM223	Computer Studies 3*
ENV131	Environmental Issues 1
GEO201	Human Geography
GEO202	Geography
MTH101	College Mathematics

\*The courses with an asterisk are worth carry 2 credits each.

✳️COM211,212,213 and214 taken before 2016 may be counted for this category.

### § b123 ADVANCED GENERAL EDUCATION COURSES

FLA students must take one of the following courses in order to fulfill their requirements for General Studies Electives subjects in the category “Advanced General Education Course”.

The syllabi of these courses can be found on the University website (syllabus inquiry) or on the Loyola.

#### Notes on Advanced General Education Courses for FLA Students

All students must take at least 2 credits of “Advanced General Education Course” as a part of GS Electives.

- Students may take the Advanced General Education Course from the fifth semester (ie. their first semester in the junior year). The priority will be given to the students in the fifth semester.
- If students take more than 2 credits of Advanced General Education Courses, he/she can count these credits as GS Electives courses.
- In principle, FLA students must choose a course(s) from the lottery courses listed below, and register during the lottery registration period.



Advanced General Education Courses for FLA students					
Registration CD	Semester offered	Course Title	Credits	Day & Time	Remarks
GSE71900	Spring	Japan in Translation	2	Mon, 2	Lottery course capacity:100
GSE71920	Spring	Social Justice in Japan	2	Mon, 4	Lottery course capacity:100
GSE71910	Autumn	Business & Management	2	Thu, 2	Lottery course capacity:100※1
GSE72080	Autumn	Catholic Social Thought and the Catholic Church Today	2	Thu, 2	Lottery course capacity:100 Priority given to FLA students

※1 Students who major in International Business and Economics cannot take GSE71910 to fulfill these requirements.

In addition to the above, FLA students may also take the course(s) below to fulfill requirement for “Advanced General Education Course.”

Note:

- Courses include Intensive Courses held during vacation, courses conducted in Japanese, and courses which instructors select students in advance.
- Students are responsible for paying the tuition and fees required for the credits, once a course has been registered on Loyola.

Courses available to Students of All Departments					
Registration CD	Semester offered	Course Title	Credits	Day & Time	Remarks
GSE70500	Spring	Bioethical Issues in the Modern Society	2	Intensive course	Lottery course capacity:90 Conducted in Japanese
GSE70810	Spring	Frontiers of Global Business	2	Intensive course	• Conducted in Japanese • Pre-screening will be conducted※2
GSE72040	Spring	Musical Theatre and Middlebrow Culture	2	Intensive course	[90]
GSE72060	Autumn	University Management	2	Fri,1	[90] Conducted in Japanese

※2 Regarding Pre-screening of GSE70810, see the bulletin board (Center for Global Discovery) on Loyola.

Internship Courses				
Registration CD	Semester Offered	Course Title	Credits	Day & Time
GSE71700	Spring	Global Internships for Senior / Junior (Short-term)	2	Intensive course
GSE71703	Spring	Global Internships (Long-term)	6	Intensive course※3
GSE70801	Spring	Volvo Group Internship Program- A Door to a World Leader in Sustainable Transport Solutions for Senior/Junior	2	Intensive course
GSE71701	Autumn	Global Internships for Senior / Junior (Short-term)	2	Intensive course
GSE71702	Autumn	Global Internships (Long-term)	6	Intensive course※3
GSE71800	Autumn	Volvo Group Internship Program- A Door to a World Leader in Sustainable Transport Solutions for Senior/Junior	2	Intensive course

Notes on Internship Courses:

- Pre-screening will be conducted for all internship courses.

As for the instruction language, please refer to course syllabi on Loyola in advance. Some courses are offered in Japanese only.

※3 Courses are held during regular class weeks. Therefore, students who participate in these courses are required to adjust their course schedule not to overlap.

- Contact the Center for Global Discovery (Bldg. No.2, B1F) for details regarding internship courses.
- In addition to the above, FLA students may also take the lottery course(s) below offered by Center for Global Discovery to fulfill requirement for “Advanced General Education Course”

Courses available to Students of All Departments offered by Global Center for Discovery					
Registration CD	Semester offered	Course Title	Credits	Day & Time	Remarks
GSE71930	Spring	Migration and Co-Existence1: Trade and Inequality	2	Wed, 5	Lottery course capacity:100 (LAP course※4)
GSE71940	Autumn	Migration and Co-Existence2: Migration and Development	2	Wed, 5	Lottery course capacity:100 (LAP course※4)

※4 “Sophia-Nanzan Latin America Program (LAP)” is a program which aims at fostering mutual understanding between Latin American countries and Japan. Focusing on the theme “Human Dignity and Harmonization”, the program offers the courses that help students gain a better understanding of global issues common to Japan and the Latin-American countries, such as diversity, social difference, cultural friction etc. The LAP courses conducted in English are open to all students.

## § b130 LANGUAGE COURSES

### • LANGUAGE CATEGORIES

#### MEDIUM OF EDUCATION

English being the medium of education in the Faculty of Liberal Arts, FLA students are reminded that English is not to be considered as a foreign language.

#### SPECIAL FOREIGN LANGUAGE

Japanese being the medium of education of most faculties in Sophia University, FLA students are reminded that Japanese must be considered as a "special foreign language".

#### OTHER FOREIGN LANGUAGE

Besides Japanese, other languages are considered as "other foreign language".

### • THE STUDY OF FOREIGN LANGUAGES

FLA students are encouraged to study languages besides English, especially Japanese. Language courses are offered by the Center for Language Education and Research (CLER) located in Bldg. No.6 (5F).

### • LANGUAGE COURSE OFFERINGS I & II

#### COURSE OFFERINGS I

A selection of languages that can be taken to fulfill the 8-credit language requirement:

- Japanese (b340)
- Chinese (b330), French (b330) and Spanish (b330). Those courses are offered for FLA students.
- Arabic, German, Indonesian, Italian, Korean, Latin, Portuguese, Russian, Tagalog (Japanese medium instruction)( Academic handbook (履修要覧) section 6).

Notice that seminar courses (演習) of Chinese, French, Spanish, German and Korean (Japanese Medium Instruction) are optional courses and cannot be counted for fulfilling the 8-credit requirement.

#### COURSE OFFERINGS II

All languages offered by the CLER including seminar courses (演習).

For university-wide courses consult the Academic handbook (履修要覧) section 6.

## § b131 GENERAL GUIDELINES

In principle, no withdrawals are allowed for language courses. Once a student withdraws from such a class, he/she will not be allowed to choose that language to fulfill the language requirement.

For lottery courses, make sure that you register during the lottery course registration period.

### LANGUAGE REQUIREMENT (LA) 8 credits

In order to fulfill their language requirement (LA), FLA students must earn **8 credits** in **one language** selected from the languages offered by the CLER (Course Offerings I). The chosen language must be taken in the correct sequence. The language chosen to fulfill the 8-credit language requirement is considered as the student's "**first foreign language**"

#### SPECIAL FOREIGN LANGUAGE (JAPANESE)

FLA students are encouraged to study Japanese.

FLA students who take Japanese to fulfill the 8 credits language requirement should take a "**Japanese Placement Test**" offered by the CLER. However, students who have never studied Japanese do not need to take the placement test.

For course registration see section b132.

#### **For students who entered before 2016:**

The language required for "non-native speakers of Japanese" who entered before 2016 is Japanese unless they demonstrate sufficient proficiency in the Japanese placement Test.

Students who entered before 2016 and who have been assigned to Japanese language **track 3** (Japanese Reading and Writing Courses) on the basis of the Japanese Placement Test and want to choose Japanese to fulfill their 8-credit language requirement, must obtain approval from the coordinator of the Japanese Language Program.

#### OTHER FOREIGN LANGUAGES (COURSE OFFERINGS I)

FLA students can take one of the following languages to fulfill their 8-credit language requirement (see restrictions for students who entered before 2016)

CHINESE, FRENCH, SPANISH (see sections b133 & b330).

ARABIC, GERMAN, INDONESIAN, ITALIAN, KOREAN, LATIN, PORTUGUESE, RUSSIAN, TAGALOG. (For more information, see sections b134&Academic handbook (履修要覧) section 6).

Seminar courses (演習) of Chinese, French, Spanish, German and Korean (Japanese Medium

Instruction) are optional courses and cannot be counted for fulfilling the 8-credit requirement.

Kentei taisaku courses (検定対策科目) cannot be included in both 8-credit requirement and SE electives.

### **GENERAL STUDIES ELECTIVES (GS)**

FLA students cannot include university-wide language courses as GS Electives.

### **FLA-WIDE SPECIALIZED EDUCATION ELECTIVES (SE ELECTIVES)**

FLA students can count credits earned taking language courses as SE electives. However, there are constraints on the number of credits in language courses FLA students can count as SE electives.

#### **SPECIAL FOREIGN LANGUAGE (JAPANESE)**

FLA students, who have taken Japanese to fulfill their 8-credit language requirement, may include up to a total of 30 credits in Japanese language as SE electives.

Those students can also choose to study another language besides Japanese selected from the languages offered by the CLER. This language will be considered as the students' "**second foreign language**" and students can count up to **8 credits** in that second language as SE electives.

Students are reminded that courses must be taken in the correct sequence.

#### **OTHER FOREIGN LANGUAGES (COURSE OFFERINGS II)**

FLA students, who have taken a language in the category "other foreign languages" (Course Offerings I) to fulfill their 8-credit language requirement, may include up to **4 additional credits of advanced courses** in the chosen language as SE electives. That language is considered as their "**first foreign language**".

In addition to their first foreign language, those students can choose to study Japanese and can count up to **30 credits** in Japanese language as SE electives.

With the study of Japanese, those students can also choose to study languages from Course Offerings II. That language will be considered as their "**second foreign language**". Students can count up to **8 credits** in that language as SE electives.

Though FLA students are not advised to do so, they can choose not to study Japanese. In that case, they can choose as their "second foreign language" one of the languages offered by the CLER. They can count up to 8 credits in that second foreign language as SE electives.

Students cannot count credits for a third foreign language.

### § b132 COURSE REGISTRATION FOR JAPANESE

Refer to the “Japanese Language Program” brochure and the Loyola bulletin board (CLER and Center for Academic Affairs).

### § b133 COURSE REGISTRATION FOR CHINESE, FRENCH, and SPANISH

[Important]

Most of the language courses offered by the Center for Language Education and Research are lottery courses (see section a330 for general information about Lottery courses). For lottery courses, make sure that you register during the lottery course registration period (see section b330 for information about which courses are lottery courses).

- Basically, students take courses from “Basic 1”, however, students who would like to choose a language they have studied before must take a “Placement Interview” before registering for a course in that language. The time schedule will be posted on Loyola before registration period.
- Students can register for courses on Loyola. However, students who take the “Placement Interview” and are admitted to take an upper-level course must submit the completed “Request for Transfer to Upper Level Course” with a signature of approval from the teacher administering the Placement Interview. After submitting it to CLER by the specified deadline, they can subsequently register their courses on Loyola.

### § b134 COURSE REGISTRATION FOR OTHER LANGUAGES

Refer to the directions described on the pages of the Gogaku Kamoku (語学科目) in the 2017 Academic Handbook (2017 年度履修要覧/2017 Nendo Rishū Yōran/).

### ATTENDANCE POLICY

In language courses offered by CLER, you are expected to actively participate and accomplish in-class tasks and activities. This class attendance is essential for your learning, and thus we have set the following rules on the required number of attendance in each course. However, meeting the attendance requirement does not guarantee your passing course units; it is only the minimum condition for the final grading, which will be done according to the specific evaluation criteria stated in the syllabus of each course.

\*For Attendance Policy of Japanese Language Courses, please refer to the “Japanese Language Program” brochure.

#### • **Twice-a-week courses (Except for Japanese Language Program)**

The total number of class sessions: **28 per semester**

The number of attendance required: At least 23 per semester

• **Once-a-week courses (Except for Japanese Language Program)**

The total number of class sessions: **14 per semester**

The number of attendance required: At least 11 per semester

- **Special Consideration**

In any of the following conditions, neither your attendance nor absence will be counted. If applicable, please ask your instructor if you can receive this special treatment.

For up to three weeks, the special treatment will apply. As for the period of absence that went beyond three weeks, regardless of the reasons you may have, the special treatment will not apply. In addition, if the absence is due to more than two circumstance stated below and exceeds three weeks, special consideration will not cover those additional days. Please ask your instructor about the required number of attendance when the special consideration is granted. If your instructor gives you an assignment to make up for your absence, the submission of the assignment becomes the prerequisite for receiving the special consideration.

1. A case of illness or injury where you submit a medical certificate indicating the necessary period of sick or injury leave. (\*1)
2. When you join the annual Jo-Nan competition or SOFEX and submit an official certificate of participation.
3. When you have been officially assigned to lay judge (裁判員/Saiban In/) and must assume the duty.
4. When you submit a certificate that confirms your attendance at teaching practice, volunteer experience study (介護等体験 /Kaigotou Taiken/), or museum practice.

(\*1) If you have chronic medical conditions and cannot specify periods of sickness or injury leave, you should consult the CLER Office (Floor 5, Bldg. 6) in advance. The deadline for informing the office is;

Friday, April 28 (Spring Semester) / Friday, October 20 (Autumn Semester)

- **Late Arrival**

Any student who fails to arrive within the first 30 minutes of a class will be regarded as being absent, even if he/she attends the rest of the class.

## § b140 FLA-WIDE SPECIALIZED EDUCATION

### § b141 FLA CORE PROGRAM

The following courses are compulsory for all students enrolled in the Faculty of Liberal Arts and must be taken during the first and second year.

ENG111 English Composition 1	4 cr
ENG112 English Composition 2	4 cr
ENG115 Public Speaking	4 cr
THP101 Thinking Processes	4 cr

#### English Placement Test and Course Assignments

Incoming students will be given an English placement test and, on the basis of the results, will be assigned to English Composition 1 or given a waiver for the course and placed in Composition 2. A few students might have their composition courses waived.

- To fulfill the total number of credits needed for graduation, students given a waiver for English Composition 1 and/or Composition 2 should take an equivalent number of credits as additional SE Electives.
- Students who do not demonstrate the English skills necessary to take English Composition 1 will first be required to take the Academic English Skills course (4 cr) / Basic Skills course (2 cr). This course will count towards graduation as FLA-wide Special Education Elective courses (SE).

#### Course Registration for FLA Core Program Courses

1. Students who are scheduled to take FLA Core Program courses are assigned to class sections at the start of each semester. These assignments cannot be changed. Students must register for the sections to which they have been assigned.
2. Students must enroll in the FLA Core Program courses in sequence. If students fail a Core Program course, they must repeat and pass the course before proceeding to the next level.
3. Neither cancellation nor withdrawal is allowed from FLA Core Program courses, including Academic English Skills / Basic Skills courses.

### § b142 MAJOR COURSES

The Department of Liberal Arts offers three majors:

**Comparative Culture**  
**International Business and Economics**  
**Social Studies**

In general, students must choose a major at the end of their third semester and meet its requirements. Each major requires students to complete 48 credits. For details, see § b150.



### § b143 FLA-WIDE SPECIALIZED EDUCATION ELECTIVES (SE)

Students should take as SE Electives a total number of 30 credits chosen from the Specialized Education courses offered by the FLA or other faculties and programs of the university.

1. **Students may count as SE Electives a maximum of 8 credits chosen from courses included on the list of FLA Distribution Courses and FLA General Courses (200 level or lower).**
2. **Students may count as SE Electives a maximum of 16 credits chosen from courses offered by other faculties and programs of the university (including 学全科目 /Gakuzen Kamoku).**
3. If a student chooses to study a language, the credits taken in that language will not be included in the 16-credit limit. Regulations for the language requirements apply. For more detail see § b130 ~ b135.
4. There are constraints on the number of credits in language courses that may be counted as FLA-wide SE electives (see § b130 ~ b135).
5. Second term first year students and above may count credits earned in the Summer Session as SE Electives.
6. University-wide General Studies Courses (全学共通科目/Zengaku Kyōtsū Kamoku) with course numbers (科目コード/Kamoku Kōdo) starting with 0 or GS courses offered by the University-wide General Studies Program (see 2017 Academic Handbook/履修要覧) may not be counted as SE Electives. However, “Human Ecology: Rivers course number 099713” taken before 2017 can be counted. Furthermore, students who entered in 2014 and 2015 can use a maximum of 2 credits of University-wide General Studies courses as FLA-wide Special Electives (SE).
7. University-wide Advanced General Education Courses may not be counted as SE Electives.
8. Credits in courses with course numbers (科目コード) starting with 62 taken in the programs for certification of junior and high school teachers (教職課程) or as curators (学芸員課程) (see 2017 年度履修要覧課程編) may not be counted fulfilling the credits required for graduation. The tuition for these courses will be waived.
9. Credits in courses with course numbers (科目コード) starting with GCP taken in the programs for Global Competency Programs may not be counted as fulfilling the credits required for graduation. The tuition for these courses will be waived.

### § b150 FLA MAJOR COURSES

#### § b151 COMPARATIVE CULTURE

The Comparative Culture major emphasizes interdisciplinary approaches to knowledge within three fields: art history/visual culture (ART), literature (LIT), and religion/philosophy (RPH). Students take 48 credits in the major distributed among a primary field and secondary field. The primary field consists of 28 credits in one of the above three fields. The secondary field consists of 20 credits taken in another field.

## COMPARATIVE CULTURE FIELDS

### ART HISTORY/VISUAL CULTURE (ART)

The field of art history and visual culture focuses on the acquisition of visual literacy across different media, from fine arts such as painting and sculpture to more contemporary media such as film and digital works, as well as ephemeral images including prints and propaganda. Art offers a rich source of knowledge concerning the human condition, providing visual records of human emotions, thought, ideals, and aspirations, as well as evidence of the social and political conditions under which people have lived, past and present.

### LITERATURE (LIT)

The field of literature offers courses in the literature of Japan, China, Britain, the United States, and continental Europe. Comparative study of the diverse literary expressions of these countries and cultures will deepen student's appreciation of the vastness of the human imagination while training them in close textual analysis, critical theory, and cultural discourse.

### RELIGION/PHILOSOPHY (RPH)

The field of comparative studies in religion/philosophy is centered on understanding the ways in which people of various historical periods and cultures have conceived, imagined, and lived out their lives in the world. Courses focus on understanding the philosophical and religious orientations of human communities as expressed in systems of thought, texts, the arts, rituals, and ethical practices.

		cr	total
Requirements for the Primary Field	Compulsory Courses		
	One 200-level Course	4	28
	One 400-level Course	4	
	Elective Comparative Culture Courses	20	
Requirements for the Secondary Field	Compulsory Course		
	One 200-level Course	4	20
	Elective Comparative Culture Courses	16	
Total			48

The following courses offered by the FLA Social Studies Area are cross-listed as FLA religion/philosophy courses. Students may include these courses as elective courses for the religion/philosophy field.

course no.	course title	cr
HST445	Religion and Society in Japan	4
POL301	Classical Western Political Theory	4

From 2015, HST439 is not offered. HST439 taken in 2014 may still be counted as an elective course for the religion/philosophy field.

## § b152 INTERNATIONAL BUSINESS AND ECONOMICS

Courses offered in this major emphasize both the development of tools of theoretical and empirical analysis and the application of these tools to the understanding of specific economic phenomena and managerial problems. The major stresses the international dimensions of both business and economics. Within this global context, special attention is given to Japanese business and economic studies.

Students majoring in International Business and Economics must complete 48 credits of IBE courses, including five 300-level courses and three 400-level courses.

		cr	total
International Business and Economics	Compulsory Courses		
	IBE200	4	48
	IBE201	4	
	Five 300-level IBE Courses	20	
	Three 400-level IBE Courses	12	
Elective IBE Courses	8		
Total			48

The following courses offered by the Faculty of Economics are cross-listed as FLA International Business and Economics courses. Students may include up to 8 credits from these courses as Elective IBE Courses, if they were cross-listed in the year when they were taken. For details on these courses refer to the 2017 Academic Handbook (2017 年度履修要覧), and course syllabi on Loyola. Some of these cross-listed courses may have prerequisites and/or require the instructor's permission due to limited enrollment places. Furthermore, students may not be able to take courses that have undergone a number or title change, if they have taken them previously under the former number or title.

course no.	course title	cr	Dept offered
407404	Econometrics 1 計量経済学 I	2	経済学科
407405	Econometrics 2 計量経済学 II	2	経済学科
467920	Asian Economy 1 アジア開発経済論	2	経済学科
467921	Asian Economy 2 アジア経済成長論	2	経済学科
430801	Logistics ロジスティクス	4	経営学科
433300	Direct Marketing ダイレクト・マーケティング	2	経営学科
438410	Auditing 1 監査論 I	2	経営学科
438420	Auditing 2 監査論 II	2	経営学科

The following courses taken before 2016 may still be counted for this category.

course no.	course title	cr	Dept offered
403101	History of Economics 1 経済学史 I	2	経済学科
403102	History of Economics 2 経済学史 II	2	経済学科
407403	Econometrics 計量経済学	4	経済学科

## § b153 SOCIAL STUDIES

The Social Studies major provides students with historical, comparative, and theoretical insights into the processes that constitute civilizations and social orders. Courses consider how particular societies and cultures have changed over time, patterns of similarity and difference across events and places, and how these patterns and processes have been interpreted and depicted in popular and scholarly imagination.

The Social Studies major has three fields: anthropology-sociology, history, and political science. Students take 48 credits in the major distributed among a primary field and secondary field. The primary field consists of 36 credits in one of the above three fields. The secondary field consists of 12 credits taken in another field. The distribution of compulsory courses varies among the different fields.

### GENERAL REQUIREMENTS

For students who entered from 2015

		cr	total
Requirements for the Primary Field	Compulsory Courses		
	One 200-level Course	4	36
	One 400-level Course	4	
	Elective Social Studies Courses	28	
Requirements for the Secondary Field	Compulsory Course		
	One 200-level Course	4	12
	Elective Social Studies Courses	8	
Total			48

**General Prerequisite:** Students entering in 2015 onward should take one of the following courses before taking a 400-level ANT/SOC course: ANT310, ANT315, ANT316, ANT317, ANT318, ANT319, SOC312, SOC315, SOC316.

For students who entered in 2014

		cr	total
Requirements for the Primary Field	Compulsory Courses	Please refer to pages 56-57	36
	200-level Courses		
300-level Courses			
	400-level Courses		
	Elective Social Studies Courses		
Requirements for the Secondary Field	Compulsory Course		12
	Elective Social Studies Courses		
Total			48

## SOCIAL STUDIES FIELDS

### ANTHROPOLOGY-SOCIOLOGY

Anthropology and sociology focus on how social orders are constituted. Although they are distinct academic disciplines, there is considerable overlap in their intellectual traditions and concerns. They are offered as an integrated field that focuses on culture and society in the making of individual identities, behavior patterns, and social institutions.

For students who entered from 2015

		Cr	total
As Primary Field	Compulsory Courses		
	One 200-level Anthropology/Sociology Course	4	36
	One 400-level Anthropology/Sociology Course	4	
	Elective Anthropology/Sociology Courses	28	
As Secondary Field	Compulsory Course		
As Secondary Field	One 200-level Anthropology/Sociology Course	4	12
	Elective Anthropology/Sociology Courses	8	
Total			48

For students who entered in 2014

		Cr	total
As Primary Field	Compulsory Courses		
	Two 200-level Anthropology/Sociology Courses including either ANT202 or SOC201	8	36
	One Methods Course chosen from ANT310, 317, 318, 319, SOC312, 315, 316, IBE340	4	
	One 400-level Anthropology/Sociology Course	4	
Elective Anthropology/Sociology Courses	20		
As Secondary Field	Compulsory Course		
	ANT202 or SOC201	4	12
	Elective Anthropology/Sociology Courses	8	

ANT313 taken in 2014 may still be counted as a Methods Course.

ANT315 and ANT316 taken before 2017 may still be counted as a Methods Course.

IBE 340 offered by the FLA International Business and Economics Area is cross-listed as an anthropology/sociology course. Students may include this course as a methods course or as an elective course for the Anthropology/Sociology field.

## HISTORY

History creates narratives and interpretations of the past with an eye toward understanding the present. This process involves asking complex questions about the experiences of humans over time. The courses encourage students to think critically about the patterns and processes that have created the modern world, with particular attention paid to the interconnectivity and transnational dimensions of East Asian history.

As Primary Field	Compulsory Courses One 200-level History Course One 400-level History Course Elective History Courses	cr	total
		4	36
		4	
28			

As Secondary Field	Compulsory Course One 200-level History Course Elective History Courses	cr	total
		4	12
		8	

The following courses offered by the Faculty of Humanities and the Faculty of Foreign Studies are cross-listed as FLA history courses. Students may include up to 8 credits from these courses as elective history courses, if they were cross-listed in the year when they were taken. For details on these courses refer to the appropriate department descriptions in the 2017 Academic Handbook (2017年度履修要覧) and course syllabi on Loyola. Some of these cross-listed courses may have prerequisites and/or require the instructor's permission due to limited enrollment places. Furthermore, students may not be able to take courses that have undergone a number or title change, if they have taken them previously under the former number or title.

course no.	course title	cr	Dept offered
170500	Confucian Ethics in the Choson Era 歴史学特講(朝鮮伝統社会と儒教倫理)	2	史学科
170470	Lecture in History (Modern Japan) 歴史学特講(日本近代史)	2	史学科
501367	Topics in American History	2	外国語学部

The following course taken before 2017 may still be counted as an elective course.

course no.	course title	cr	Dept offered
165814	Confucian Ethics in the Choson Era 東洋史特講(朝鮮伝統社会と儒教倫理)	2	史学科

The following courses taken before 2016 may still be counted as elective courses.

course no.	course title	cr	Dept offered
160711	Problems in History 歴史学をめぐる諸問題	2	史学科
501316	Topics in American History 1 (旧 Topics in American History I「米国史特講I」)	2	外国語学部
501317	Topics in American History 2 (旧 Topics in American History II「米国史特講II」)	2	外国語学部

## POLITICAL SCIENCE

Political Science focuses on the study of the state, government, and politics. It is particularly concerned with questions such as how power and authority are exercised and how that exercise leads to conflict or to the promotion of peaceful relations among social actors and states.

For students who entered from 2015

		cr	total
As Primary Field	Compulsory Courses		
	One 200-level Political Science Course	4	36
	One 400-level Political Science Course	4	
	Elective Political Science Courses	28	

		cr	total
As Secondary Field	Compulsory Course		
	One 200-level Political Science Course	4	12
	Elective Political Science Courses	8	

For students who entered in 2014

		cr	total
As Primary Field	Compulsory Courses		
	Two 200-level Political Science Courses	8	36
	Two 400-level Political Science Courses	8	
	Elective Political Science Courses	20	

		cr	total
As Secondary Field	Compulsory Course		
	One 200-level Political Science Course	4	12
	Elective Political Science Courses	8	



## § b160 SELF-EVALUATION

Students are responsible for checking if they have received enough credits for graduation.

Students are responsible for checking the FLA Bulletin of Information and see if they are fulfilling the requirements towards graduation.

The Self-evaluation system of the Loyola is one of the many tools offered to FLA students to check if they are taking the right courses for fulfilling all the requirements towards graduation.

## IMPORTANT CONSTRAINTS FOR MEETING GRADUATION REQUIREMENTS

### § b161 GS ELECTIVES

- 12 credits of GS Electives from at least 2 of the 3 categories of FLA Distribution Courses
- 2 credits of Advanced General Education Course

### § b162 FLA SE ELECTIVES

#### **No Constraints:**

- Summer Session in Asian Studies credits (Second semester and above students)
- FLA 300-400 level courses

#### **Constraints:**

- No more than 8 credits of FLA Distribution Courses and FLA General Courses (100-200 level courses)
- No more than 16 credits of courses offered by other faculties and programs of the university including “Gakuzen Kamoku” courses.
- No more than 30 credits of Japanese
- No more than 4 credits of advanced courses in the same language selected to fulfill Language requirements
- No more than 8 credits in a second language

#### **Forbidden**

- No course starting with 0 or GS offered by the University-wide General Studies Program. However, “Course No. 099713 Human Ecology: Rivers” taken in 2015, 2016 can be counted. Furthermore, students who entered in 2014 and 2015 can use a maximum of 2 credits of University-wide General Studies courses as FLA-wide Special Education Electives (SE)\*.
- No course starting with 62
- No third language credits (except for Japanese)
- No Advanced General Education Courses
- No Studies in Christian Humanism

\*In case students who entered in 2014 and 2015 would like to include 2 credits of a GS course (or two GS courses) in SE Electives, they need to complete an application procedure for this at the Center for Academic Affairs. For details, please consult the Center.

## § b200 CURRICULUM FOR STUDENTS WHO ENTERED BEFORE 2014

### § b210 【For students who entered from 2011 to 2013】

The curriculum is divided into two parts:

General Studies (GS)

Specialized Education (SE)

<b>General Studies</b>	<b>30 credits</b>
<b>Compulsory courses</b>	
Compulsory courses(必修科目)	
Health and Physical Education	2 cr
Language	8 cr
Compulsory Electives Courses(選択必修科目)	
Studies in Christian Humanism	4 cr
GS Distribution Courses	12 cr
GS Electives	4 cr
<b>Specialized Education</b>	<b>94 credits</b>
FLA Core Program	
Thinking Processes	4 cr
English Composition 1	4 cr
English Composition 2	4 cr
Public Speaking	4 cr
Major Courses	48 cr
SE Electives	30 cr
<b>A total of 124 credits is required for graduation.</b>	

### § b220 【For students who entered before 2011】

The curriculum is divided into two parts:

General Studies (GS)

Specialized Education (SE)

<b>General Studies</b>	<b>32 credits</b>
Compulsory courses	
Compulsory Courses(必修科目)	
Health and Physical Education	2 cr
Language	8 cr
Information Literacy	2 cr
Compulsory Elective courses(選択必修科目)	
Studies in Christian Humanism	4 cr
GS Distribution Courses	12 cr
GS Electives	4 cr
<b>Specialized Education</b>	<b>92 credits</b>
FLA Core Program	
Thinking Processes	4 cr
English Composition 1	4 cr
English Composition 2	4 cr
Public Speaking	4 cr
Major Courses	48 cr
SE Electives	28 cr
<b>A total of 124 credits is required for graduation.</b>	

## § b230 GENERAL STUDIES

### § b231 STUDIES IN CHRISTIAN HUMANISM

Two courses in the category “Studies in Christian Humanism” (キリスト教人間学) for a total of 4 credits are compulsory for all students who are enrolled in the Faculty of Liberal Arts. Normally, students must take one course in their first semester and another the second semester.

Registration CD	Semester	Course Title	Credits
GSG19110	Spring	Philosophy of the Human Person	2
GSG18910	Spring	Philosophy of Human Rights and Human Dignity	2
GSG18920	Spring	Philosophy of Religious Language	2
GSG19510	Spring	Freedom and Leadership : Ignatian Spirituality for Life	2
GSG19740	Autumn	Philosophy of the Human Person	2
GSG18930	Autumn	Philosophy of Religious Language	2
GSG19370	Autumn	Philosophy of Human Nature	2
GSG19410	Autumn	Freedom and Leadership : Ignatian Spirituality for Life	2

Please note that places in these courses will be chosen by lottery, so students should register for these courses during the **lottery registration period**. Details will be announced on Loyola Bulletin Board (Academic Services).

#### **For students who entered before 2010 and have not yet taken Philosophical Anthropology 1 and 2:**

Philosophical Anthropology 1 and 2 are no longer offered. The students who have not yet taken or have failed them must take a total of two courses from the above list.

The students should register for these courses during the lottery registration period.

## § b232 LANGUAGE COURSES

Students must gain 8 credits in one language chosen from the language courses offered by the Center for Language Education and Research (CLER). Courses offered are as follows:

- **Chinese, French, Spanish** (Courses are conducted in English and are exclusive to FLA students)
- **Japanese** (English medium instruction)
- **Arabic, German, Indonesian, Italian, Korean, Latin, Portuguese, Russian, Tagalog** (Japanese medium instruction)

N.B.

1. Students are encouraged to select a language that they have not previously studied. A student who chooses a language he or she has studied previously and is placed at an advanced level may encounter difficulties in completing the required 8 credits in one language.
2. The language required for non-native speakers of Japanese is Japanese unless they demonstrate sufficient proficiency in the Japanese Placement Test.
3. Students who are assigned to Japanese language track 3 (Japanese Reading and Writing Courses) on the basis of the Japanese placement test and want to choose Japanese to fulfill their language requirements must obtain approval from the coordinator of the Japanese Language Program. Please consult the Center for Language Education and Research for further information on procedures.
4. Language courses must be taken in the correct sequence. Credit will not be counted for a language course of a level lower than one taken previously for the graduation requirement.
5. Students who wish to continue study of a language other than Japanese beyond the required 8 credits may include additional credits in their SE Electives as specified below:
  - a. Up to 4 credits of advanced courses in the same language selected to fulfill the language requirement may be included in the student's SE Electives.
  - b. Up to 8 credits in a second language may be included as SE Electives.
  - c. Apart from Japanese, the credits for a third language cannot be counted for graduation.
6. Regardless of whether the student is a native or non-native speaker of Japanese, students who entered from 2011 may include up to a total of 30 credits in Japanese as SE Electives. For those who entered before 2011, 28 credits may be counted as SE Electives.
7. In principle, no withdrawals are allowed for any language courses. Once a student withdraws from such a class, he/she will not be allowed to choose that language to fulfill the language requirement.
8. Note that many language courses are lottery courses. Make sure you register the lottery courses during the lottery course registration period.

### ■ Course Registration for **Chinese, French, or Spanish Courses offered for FLA students**

[Important]

Most of the language courses offered by the Center for Language Education and Research are lottery courses (see section a330 for general information about Lottery courses). For lottery courses, make sure that you register during the lottery course registration period (see section b330 for information about which courses are lottery courses).

Basically, students take courses from “Basic 1”, however, students opting to take a language which they have studied before, they will take a “Placement Interview” before the registration of that language. The time schedule will be posted on Loyola before registration period.

Students can register for courses on Loyola. However, the students who take the “Placement Interview” and are admitted to take an upper-level course must submit the completed “Request for Transfer to Upper Level Course” with a signature of approval from the teacher administering the Placement Interview. After submitting it to CLER by the specified deadline, they can subsequently register their courses on Loyola.

### ■ Course Registration for **Japanese**

Please refer to the “Japanese Language Program” brochure and Loyola Bulletin Board (CLER and Center for Academic Affairs).

### ■ Course Registration for **Other Languages**

Please refer to the directions described on the pages of “語学科目” in 2017 Academic Handbook (2017 年度履修要覧).

## ATTENDANCE POLICY

In language courses offered by CLER, you are expected to actively participate and accomplish in-class tasks and activities. This class attendance is essential for your learning, and thus we have set the following rules on the required number of attendance in each course. However, meeting the attendance requirement does not guarantee your passing course units; it is only the minimum condition for the final grading, which will be done according to the specific evaluation criteria stated in the syllabus of each course.

\*For Attendance Policy of Japanese Language Courses, please refer to the “Japanese Language Program” brochure.

#### • **Twice-a-week courses (Except for Japanese Language Program)**

The total number of class sessions: **28 per semester**

The number of attendance required: At least 23 per semester

#### • **Once-a-week courses (Except for Japanese Language Program)**

The total number of class sessions: **14 per semester**

The number of attendance required: At least 11 per semester

**- Special Consideration**

In any of the following conditions, neither your attendance nor absence will be counted. If applicable, please ask your instructor if you can receive this special treatment.

For up to three weeks, the special treatment will apply. As for the period of absence that went beyond three weeks, regardless of the reasons you may have, the special treatment will not apply. In addition, if the absence is due to more than two circumstance stated below and exceeds three weeks, special consideration will not cover those additional days. Please ask your instructor about the required number of attendance when the special consideration is granted. If your instructor gives you an assignment to make up for your absence, the submission of the assignment becomes the prerequisite for receiving the special consideration.

1. A case of illness or injury where you submit a medical certificate indicating the necessary period of sick or injury leave. (\*1)
2. When you join the annual Jo-Nan competition or SOFEX and submit an official certificate of participation.
3. When you have been officially assigned to lay judge (裁判員/Saiban In/) and must assume the duty.
4. When you submit a certificate that confirms your attendance at teaching practice, volunteer experience study (介護等体験 /Kaigotou Taiken/), or museum practice.

(\*1) If you have chronic medical conditions and cannot specify periods of sickness or injury leave, you should consult the CLER Office (Floor 5, Bldg. 6) in advance. The deadline for informing the office is;

Friday, April 28 (Spring Semester) / Friday, October 20 (Autumn Semester)

**- Late Arrival**

Any student who fails to arrive within the first 30 minutes of a class will be regarded as being absent, even if he/she attends the rest of the class.

## § b233 HEALTH AND PHYSICAL EDUCATION

“Wellness, the Body and Culture” (ウエルネスと身体), 2 credits, is compulsory for all students entering from 2009. This course should be taken in the semester the student enters the university. The compulsory course in Health and Physical Education for students who entered between 2006 and 2008 is “Theory and Practice of Wellness” (ウエルネスの理論と実践); students who have not taken this course should take “Wellness, the Body and Culture” (ウエルネスと身体). The course will be offered in Japanese and English. Students will be assigned to the appropriate class. An adapted course for students with disabilities will be offered spring semester.

Students who entered before 2017 cannot register online via Loyola.

\*For students who entered before 2017 and have not completed “Wellness, the Body and Culture”, students who entered before 2009 and have not completed “Theory and Practice of Wellness”(ウエルネスの理論と実践), and transfer students who have not completed compulsory HPE those students should take ‘Wellness, the Body and Culture’. To register the course, the students must come to the meeting room of HPE department (Bldg. No.7, 2F, 220) for registration on April 5 (Wed) 10 : 00~12:00 for Spring semester, or on September 20 (Wed) 10:00~12:00 for Autumn semester. Please note that registration is on a first-come-first-served basis and the number of acceptance is limited.

Class will be assigned and a permission sheet will be issued at the registration and it should be submitted to the Center for Academic Affairs during the period below.

Submission period of permission sheet (During office hours)

Spring semester : April 12 (Wed) – April 18 (Tue)

Autumn semester : September 27 (Wed) – October 3 (Tue)

\*For students with disabilities

“Wellness, the Body and Culture” Adapted class will be held on Friday at 11:00-12:30 in spring semester.



---

## § b234 INFORMATION LITERACY

The course of “Information Literacy”(情報リテラシー), with 2 credits, is compulsory for students who entered before 2011. Students who have not yet taken this course should take it in 2017. Students can choose the course offered in English or Japanese. Students should register during the lottery registration period. Neither cancellation nor withdrawal is allowed for this course.

## § b235 GS DISTRIBUTION AND ELECTIVE COURSES

The courses offered by the Faculty of Liberal Arts as part of the General Studies program provide an introduction to major themes and approaches to study in various key areas of human knowledge.

Students entering prior to 2014 must take one course from each of the three categories of GS Distribution Courses (Legacy of the Past, Cultural Traditions, and Contemporary World) for a total of 12 credits. In addition to the 12 credits of GS Distribution Courses, students must take a further 4 credits as GS Electives. These 4 credits may be chosen from (a) any of the three categories of GS Distribution Courses, (b) FLA General Studies Elective Courses, or (c) any courses listed in the University-wide General Studies Program University-wide General Studies Courses (全学共通科目).

Some courses are listed under both General Studies and Specialized Education categories and may be chosen to fulfill requirements in either category. However, the same course may not be used to fulfill requirements in both categories simultaneously.

---

## § b240 CATEGORIES AND LIST OF COURSES (for students entered before 2014)

### § b241 GENERAL STUDIES DISTRIBUTION COURSES

**Legacy of the Past:** The courses in this category introduce students to the experiences of different human societies, from ancient times to more recent periods. They look at the development of institutional, intellectual, and social patterns that continue to influence our ways of thinking and acting today.

HST251	Development of Japanese Civilization 1
HST252	Development of Japanese Civilization 2
HST261	History of Chinese Civilization

**Cultural Traditions:** From the very beginning humans have sought to communicate their ideas about themselves, their societies, and the world. The courses in this category introduce written and artistic expressions of human creativity. They provide students with experience in the analysis and interpretation of particular literary texts, philosophic concepts, works of art, systems of belief, and symbolic structures.

ART201	Introduction to Art History/Visual Culture 1
ART250	Introduction to Art History/Visual Culture 2
LIT201	Literary Genres
LIT231	Introduction to Japanese Literature
RPH201	Introduction to Philosophy
RPH202	Fundamentals of Religion

※LIT260 and 270 taken in 2015 may still be counted for this category.

**Contemporary World:** Social, political, and economic factors play a major role in shaping the world in which we live. The courses in this category introduce students to some of the major approaches for investigating the nature and impact of such factors.

ANT202	Introduction to Cultural and Social Anthropology
ANT220	Anthropology of Japan
ANT230	Culture and Identity
IBE200	Principles of Microeconomics
IBE201	Principles of Macroeconomics
POL201	Theories and Themes of Contemporary Politics
POL205	Introduction to International Relations
POL210	Introduction to Comparative Politics
POL215	Controversies in Globalization
SOC201	Introduction to Sociology
SOC210	Introduction to Social Theory
SOC225	Introduction to Japanese Society

---

**§ b242 GENERAL STUDIES ELECTIVE COURSES**

COM221	Computer Studies 1*
COM222	Computer Studies 2*
COM223	Computer Studies 3*
ENV131	Environmental Issues 1
GEO201	Human Geography
GEO202	Geography
LNG210	Introduction to Linguistics
MTH101	College Mathematics
MTH111	Mathematics and Statistics for Business and Economics

※COM211, 212, 213 and 214 taken before 2016 may still be counted for this category.

**Note**

1. The courses with asterisk carry 2 credits each.
2. There are changes in the list of FLA GS Distribution and Elective Courses. The courses will only be counted as GS Electives if they were taken in the year when they were listed as GS Electives. They may still be counted as SE Electives.
3. Students who have scheduling difficulties in fulfilling graduation requirements in the category of “Legacy of the Past” should consult the FLA Chair.

---

## § b250 SPECIALIZED EDUCATION

### § b251 FLA CORE PROGRAM

The following courses are compulsory for all students enrolled in the Faculty of Liberal Arts and must be taken during the first and second year.

ENG111	English Composition 1	4 cr
ENG112	English Composition 2	4 cr
ENG115	Public Speaking	4 cr
THP101	Thinking Processes	4 cr

#### English Placement Test and Course Assignments

Incoming students will be given an English placement test and, on the basis of the results, will be assigned to English Composition 1 or 2 or given a waiver for the course. To fulfill the total number of credits needed for graduation, students given a waiver for English Composition 1 or 2 should take an equivalent number of credits as additional SE Electives. Any student who does not demonstrate the English skills necessary to take English Composition 1 will first be required to take Basic Skills (2, 4 credits ). This course will count towards graduation as SE Electives.

#### Course Registration for FLA Core Program Courses

1. Students who are scheduled to take FLA Core Program courses are assigned to class sections at the start of each semester. These assignments cannot be changed. Students must register for the sections to which they have been assigned.
2. Students must enroll in the FLA Core Program courses in sequence. If a student fails a Core Program course (including Basic Skills), he/she must repeat and pass the course before proceeding to the next level.
3. Neither cancellation nor withdrawal is allowed from FLA Core Program courses, including Basic Skills.

## § b252 MAJOR COURSES

The Department of Liberal Arts offers three majors:

**Comparative Culture**  
**International Business and Economics**  
**Social Studies**

Students must choose a major at the end of their third semester and meet its requirements. Each major requires students to complete 48 credits. For details, see the sections § b260.

Students can take any level courses for major electives' categories which are chosen by students.

## § b253 SPECIALIZED EDUCATION ELECTIVES

Students should take as SE Electives a total number of 30 credits chosen from the Specialized Education courses offered by the Faculty of Liberal Arts or other faculties and programs of the university. Those who entered before 2011 should take 28 credits as SE Electives.

N.B.

1. **Students may count as SE Electives a maximum of 8 credits chosen from courses included on the list of FLA General Studies Courses.**
2. **Students may count as SE Electives a maximum of 16 credits chosen from courses offered by other faculties and programs of the university (including “Gakuzen Kamoku” 学全科目).** If a student chooses to study a language, the credits taken in that language will not be included in the 16-credit limit. Regulations for the language requirement apply. Please see § b232 for more details.
3. There are regulations concerning the number of credits in language courses that may be counted as SE Electives (see § b232).
4. Second-term first-year students and above may count credits earned in the Summer Session as SE Electives.
5. University-wide General Studies Courses (全学共通科目) courses with course numbers (科目コード) starting with 0 or GS offered by the University-wide General Studies Program (see 2017Academic Handbook: 2017 年度履修要覧) may not be counted as SE Electives. **However the course “Human Ecology: Rivers”, course number:099713 taken before 2017, can be counted as SE Electives.**

6. Credits in courses with course numbers (科目コード) starting with 62 taken in the programs for certification as junior and high school teachers (教職課程) or as curators (学芸員課程) (see 2017年度履修要覧課程編) may not be counted as fulfilling the credits required for graduation. The tuition for these courses will be waived.
7. Credits in courses with course numbers (科目コード) starting with GCP taken in the programs for Global Competency Programs may not be counted as fulfilling the credits required for graduation. The tuition for these courses will be waived.

Courses	SE electives	Remarks
FLA General Studies Courses (100-200 level Courses)	○	8 credits maximum See § b241, § b242 for course list
FLA 300-400 level Courses	○	
University-wide General Studies Courses* (全学共通科目)	×	* Except for "Human Ecology: Rivers" course number:099713 taken in 2015, 2016 See 2017 Academic Handbook :2017年度履修 要覧
Advanced General Education Subjects (高学年向け教養科目)	×	
Studies in Christian Humanism	×	
Specialized education courses offered by other faculties (including Gakuzen Kamoku)	○	16 credits maximum
Language Courses	○	Japanese, second language, advanced level of the language selected for the language requirement may be included. See § b232 for regulations in detail concerning credits
Sophia Summer Session Courses	○	
Credits in course numbers starting with 62 (courses in the programs for certification as junior and high school teachers or as curators 教 職課程、学芸員課程)	×	See 2017年度履修要覧課程編
Credits in course numbers starting with GCP (Global Competency Programs Courses)	×	See 2017Academic Handbook: 2017年度履修要覧

## § b260 MAJOR COURSES

### § b261 COMPARATIVE CULTURE

The Comparative Culture major emphasizes interdisciplinary approaches to knowledge within three fields: art history, literature, and religion-philosophy. Students take 48 credits in the major distributed among a primary and secondary field.

For students who entered before 2014, the primary field consists of 36 credits in one of the above three fields. At least 4 credits in the primary field should be a 400-level course. The secondary field consists of 12 credits taken in another field.

### GENERAL REQUIREMENTS

		cr	total
Requirements for the Primary Field	Compulsory Courses		
	One 200-level Course	4	36
	One 400-level Course	4	
Elective Comparative Culture Courses	28		
Requirements for the Secondary Field	Compulsory Course	4	12
	Elective Comparative Culture Courses	8	
Total			48

## COMPARATIVE CULTURE FIELDS

### ART HISTORY

The discipline of art history covers all fields of art: from sculpture, architecture, painting, and crafts, to applied and industrial arts. Art is a rich source of knowledge concerning the human condition, providing visual records of human emotions, thought, ideals, and aspirations, as well as evidence of the social and political conditions under which people have lived, past and present.

#### For students entering from 2009 to 2013

		cr	total
As Primary Field	Compulsory Courses		
	ART201 or ART250	4	36
	One 400-level Art Course	4	
Elective Art Courses	28		

		cr	total
As Secondary Field	Compulsory Course		
	ART201 or ART250	4	12
	Elective Art Courses	8	

From 2014, ART230 is not offered. ART230 taken before 2014 may still be counted as a compulsory course.

### LITERATURE

The field of literature offers courses in the literature of Japan, China, Britain, the United States, and continental Europe. Comparative study of the diverse literary expressions of these countries and cultures will deepen students' appreciation of the vastness of the human imagination while training them in close textual analysis, critical theory, and cultural discourse.

		cr	total
As Primary Field	Compulsory Courses		
	LIT201 or LIT231	4	36
	One 400-level Literature Course	4	
Elective Literature Courses	28		

		cr	total
As Secondary Field	Compulsory Course		
	LIT201 or LIT231	4	12
	Elective Literature Courses	8	

From 2014, LIT202 is not offered. LIT202 taken before 2014 may still be counted as a compulsory course.



## RELIGION-PHILOSOPHY

The field of comparative studies in religion-philosophy is centered on understanding the ways in which people of various historical periods and cultures have conceived, imagined, and lived out their lives in the world. Courses focus on understanding the philosophical and religious orientations of human communities as expressed in systems of thought, texts, the arts, rituals, and ethical practices.

		cr	total
As Primary Field	Compulsory Courses		
	RPH201 or RPH202	4	36
	One 400-level RPH Course	4	
Elective RPH Courses	28		

		cr	total
As Secondary Field	Compulsory Course		
	RPH201 or RPH202	4	12
	Elective RPH Courses	8	

From 2014, RPH203 is not offered. RPH203 taken before 2014 may still be counted as a compulsory course.

The following courses offered by the FLA Social Studies Area are cross-listed as FLA religion/philosophy courses. Students may include these courses as elective courses.

course no.	course title	cr
HST445	Religion and Society in Japan	4
POL301	Classical Western Political Theory	4

The following two courses taken before 2015 may still be counted as elective courses.

course no.	course title	cr
HST412	Readings in European Sources	4
HST439	Issues in Japanese History and Thought	4

## § b262 INTERNATIONAL BUSINESS AND ECONOMICS

Courses offered in this major emphasize both the development of tools of theoretical and empirical analysis and the application of these tools to the understanding of specific economic phenomena and managerial problems. The major stresses the international dimensions of both business and economics. Within this global context, special attention is given to Japanese business and economic studies.

Students majoring in International Business and Economics must complete 48 credits of IBE courses, including five 300-level courses and three 400-level courses.

		cr	total
International Business and Economics	Compulsory Courses		
	IBE200	4	48
	IBE201	4	
	Five 300-level IBE Courses	20	
	Three 400-level IBE Courses	12	
Elective IBE Courses	8		
Total			48

The following courses offered by the Faculty of Economics are cross-listed as FLA International Business and Economics courses. Students may include up to 8 credits from these courses as Elective IBE Courses, if they were cross-listed in the year when they were taken. For details on these courses refer to the 2017 Academic Handbook (2017年度履修要覧), and course syllabi on Loyola. Some of these cross-listed courses may have prerequisites and/or require the instructor's permission due to limited enrollment places. Furthermore, students may not be able to take courses that have undergone a number or title change, if they have taken them previously under the former number or title.

course no.	course title	cr	Dept offered
407404	Econometrics 1 計量経済学 I	2	経済学科
407405	Econometrics 2 計量経済学 II	2	経済学科
467920	Asian Economy 1 アジア開発経済論	2	経済学科
467921	Asian Economy 2 アジア経済成長論	2	経済学科
430801	Logistics ロジスティクス	4	経営学科
433300	Direct Marketing ダイレクト・マーケティング	2	経営学科
438410	Auditing 1 監査論 I	2	経営学科
438420	Auditing 2 監査論 II	2	経営学科

The following courses taken before 2016 may still be counted for this category.

course no.	course title	cr	Dept offered
403101	History of Economics 1 経済学史 I	2	経済学科
403102	History of Economics 2 経済学史 II	2	経済学科
407403	Econometrics 計量経済学	4	経済学科

## § b263 SOCIAL STUDIES

The Social Studies major provides students with historical, comparative, and theoretical insights into the processes that constitute civilizations and social orders. Courses consider how particular societies and cultures have changed over time, patterns of similarity and difference across events and places, and how these patterns and processes have been interpreted and depicted in popular and scholarly imagination.

The Social Studies major has three fields: anthropology-sociology, history, and political science. Students take 48 credits in the major distributed among a primary field and secondary field. The primary field consists of 36 credits in one of the above three fields. The secondary field consists of 12 credits taken in another field. The distribution of compulsory courses varies among the different fields.

### GENERAL REQUIREMENTS

		cr	total
Requirements for the Primary Field	Compulsory Courses 200-level courses 300-level courses 400-level courses  Elective Social Studies Courses	Please refer to pages 79-80	36
Requirements for the Secondary Field	Compulsory Course Elective Social Studies Courses		12
Total			48

## SOCIAL STUDIES FIELDS

### ANTHROPOLOGY-SOCIOLOGY

Anthropology and sociology focus on how social orders are constituted. Although they are distinct academic disciplines, there is considerable overlap in their intellectual traditions and concerns. They are offered as an integrated field that focuses on culture and society in the making of individual identities, behavior patterns, and social institutions.

As Primary Field	Compulsory Courses	cr	total
	Two 200-level Anthropology/Sociology Courses including either ANT202 or SOC201	8	36
	One Methods Course chosen from ANT310, 317, 318, 319, SOC312, 315, 316, IBE340	4	
	One 400-level Anthropology/Sociology Course	4	
Elective Anthropology/Sociology Courses	20		
As Secondary Field	Compulsory Course: ANT202 or SOC201	4	12
	Elective Anthropology/Sociology Courses	8	

- IBE340 may be included as a Methods Course or as an elective course.
- From 2015, ANT313 is not offered. ANT313 taken before 2014 may still be counted as a Methods Course.
- From 2017, ANT315 and ANT316 are not offered. ANT315 and ANT316 taken before 2017 may still be counted as Methods Courses.
- From 2014, IBE426 is not offered. IBE426 taken before 2014 may still be counted as an elective course.

### HISTORY

History creates narratives and interpretations of the past with an eye toward understanding the present. This process involves asking complex questions about the experiences of humans over time. The courses encourage students to think critically about the patterns and processes that have created the modern world, with particular attention paid to the interconnectivity and transnational dimensions of East Asian history.

As Primary Field	Compulsory Courses Two 400-level History Courses Elective History Courses	cr	total
		8 28	36

As Secondary Field	Elective History Courses	cr	total
		12	12

The following courses offered by the Faculty of Humanities and the Faculty of Foreign Studies are cross-listed as FLA history courses. Students may include up to 8 credits from these courses as elective history courses, if they were cross-listed in the year when they were taken. For details on these courses refer to the appropriate department descriptions in the 2017 Academic Handbook (2017 年度履修要覧) and course syllabi on Loyola. Some of these cross-listed courses may have prerequisites and/or require the instructor's permission due to limited enrollment places. Furthermore, students may not be able to take courses that have undergone a number or title change, if they have taken them previously under the former number or title.

course no.	course title	cr	Dept offered
170500	Confucian Ethics in the Choson Era 歴史学特講(朝鮮伝統社会と儒教倫理)	2	史学科
170470	Lecture in History (Modern Japan) 歴史学特講(日本近代史)	2	史学科
501367	Topics in American History	2	外国語学部

The following course offered by Faculty of Foreign Studies was cross-listed as a FLA History course for 2012. The course taken in 2012 may still be counted as an elective course.

course no.	course title	cr	Dept offered
607123	Life and Writings of Joze Rizal	2	アジア文化 副専攻

The following course taken before 2017 may still be counted as an elective course.

course no.	course title	cr	Dept offered
165814	Confucian Ethics in the Choson Era 東洋史特講(朝鮮伝統社会と儒教倫理)	2	史学科

The following courses taken before 2016 may still be counted an elective courses.

course no.	course title	cr	Dept offered
160711	Problems in History 歴史学をめぐる諸問題	2	史学科
501316	Topics in American History 1 (旧 Topics in American History I「米国史特講I」)	2	外国語学部
501317	Topics in American History 2 (旧 Topics in American History II「米国史特講II」)	2	外国語学部

## POLITICAL SCIENCE

Political Science focuses on the study of the state, government, and politics. It is particularly concerned with questions such as how power and authority are exercised and how that exercise leads to conflict or to the promotion of peaceful relations among social actors and states.

		cr	total
As Primary Field	Compulsory Courses		
	Two 200-level Political Science Courses	8	36
	Two 400-level Political Science Courses	8	
	Elective Political Science Courses	20	

		cr	total
As Secondary Field	Compulsory Course		
	One 200-level Political Science Course	4	12
	Elective Political Science Courses	8	

IBE470 taken before 2011 may still be counted as an elective course.

The following courses offered by the Faculty of Global Studies are cross-listed as FLA political science courses.

**For Social Studies area students who entered before 2011 and choose the political science field as their primary or secondary field**, the courses listed below may be counted as electives (up to 8 credits).

course no.	course title	cr	Dept offered
BGS57602/ 608940	演習 (グローバル・国際研究) 1 (旧「演習 (国際関係論 A)」*) Seminar (Global & International Studies)1	2	総合グローバル学部 (2016-) 外国語学部 (-2015)
BGS57603/ 608941	演習 (グローバル・国際研究) 2 (旧「演習 (国際関係論 A)」*) Seminar (Global & International Studies)2	2	総合グローバル学部 (2016-) 外国語学部 (-2015)
BGS52400/ 600641	Foreign Policy 1 外交政策 1	2	総合グローバル学部 (2015-) 外国語学部 (-2014)
BGS52401/ 600642	Foreign Policy 2 外交政策 2	2	総合グローバル学部 (2015-) 外国語学部 (-2014)

**For Social Studies area students who entered before 2011 and choose the political science field as their primary or secondary field**, the following courses taken before 2014 may still be counted as elective courses.

course no.	course title	cr	Dept offered
605123	Seminar (Comparative Politics 1) 演習 (比較政治学 1)	2	外国語学部
605124	Seminar (Comparative Politics 2) 演習 (比較政治学 2)	2	外国語学部

**For Social Studies area students who entered in 2011 and 2012 and choose the political science field as their primary or secondary field, the courses listed below may still be counted as electives (up to 8 credits).**

course no.	course title	cr	Dept offered
BGS57602/ 608940	演習 (グローバル・国際研究) 1 (旧「演習 (国際関係論 A)」*) Seminar (Global & International Studies)1	2	総合グローバル学部 (2016-) 外国語学部 (-2015)
BGS57603/ 608941	演習 (グローバル・国際研究) 2 (旧「演習 (国際関係論 A)」*) Seminar (Global & International Studies)2	2	総合グローバル学部 (2016-) 外国語学部 (-2015)
BGS52400/ 600641	外交政策 1 Foreign Policy 1	2	総合グローバル学部 (2015-) 外国語学部 (-2014)
BGS52401/ 600642	外交政策 2 Foreign Policy 2	2	総合グローバル学部 (2015-) 外国語学部 (-2014)

**For Social Studies area students who entered before 2013 and choose the political science field as their primary or secondary field, the following courses taken before 2014 may still be counted as elective courses.**

course no.	course title	cr	Dept offered
537914	European Politics 1 ヨーロッパ政治論 1	2	ドイツ語学科
601403	Peace Research	4	国際関係副専攻

**For Social Studies area students who entered in 2013 and choose the political science field as their primary or secondary field, the courses listed below may be counted as electives.**

course no.	course title	cr	Dept offered
BGS57602/ 608940	演習 (グローバル・国際研究) 1 (旧「演習 (国際関係論 A)」*) Seminar (Global & International Studies)1	2	総合グローバル学部 (2016-) 外国語学部 (-2015)
BGS57603/ 608941	演習 (グローバル・国際研究) 2 (旧「演習 (国際関係論 A)」*) Seminar (Global & International Studies)2	2	総合グローバル学部 (2016-) 外国語学部 (-2015)

For details on the courses refer to the 2017 Academic Handbook(2017年度履修要覧), and course syllabi on the Loyola system. Students may not be able to take courses that have undergone a number or title change, if they have taken them previously under the former number or title.

\*From 2014, 604522 International Relations A/「演習 (国際関係論 A)」is not offered. 604522 taken before 2014 may still be counted as an elective course.





## § b300 COURSE LISTS

### § b310 FLA COURSE LISTS

Some FLA courses have the same course numbers as courses taught in other faculties. Note that credits from these courses of the other faculties may only count toward fulfilling the requirement for Specialized Education Electives.

- (A) : Adjunct Instructor  
 (1) : Every Other Year  
 (R) : Can be repeated for graduation credit with the instructor's permission  
 (L) [ ] : Lottery Course. Number in brackets is the capacity  
 (J) : Check the Syllabus of these courses on Loyola to see if they are offered in English or in Japanese  
 ☆ : These courses cannot be taken by students who took the courses with their former number or title.  
 (C) : Students entering in 2015 onward should take one of the following courses before taking a 400-level ANT/SOC course :  
 ANT310, ANT315, ANT316, ANT317, ANT318, ANT319, SOC312, SOC315, SOC316  
 (X) : ANT302 and POL304 must be taken together in the same semester and require students to submit an application. For more information, please contact the FLA office.

- E : Offered by Faculty of Economics  
 F : Offered by Faculty of Foreign Studies  
 G : Offered by Faculty of Global Studies  
 H : Offered by Faculty of Humanities

Courses with blank in "Semester offered" are not offered in 2017.

For descriptions of the courses listed below, please refer to course syllabi on Loyola.

SPR: Spring

AUT: Autumn

blank: not offered in 2017

#### GENERAL STUDIES

Registration CD	Course CD	Course Title	Cr.	Semester Offered	Instructor	Student Year	Remarks
ACOM221A	COM221	COMPUTER STUDIES 1	2	AUT	BOSSIEUX Eric	1·2·3·4	(A) (L)[40] ☆ Formerly COM211
ACOM221B	COM221	COMPUTER STUDIES 1	2	SPR	SUGIMOTO Toyohiko	1·2·3·4	(A) (L)[32] ☆ Formerly COM211
ACOM221C	COM221	COMPUTER STUDIES 1	2	SPR	SUGIMOTO Toyohiko	1·2·3·4	(A) (L)[32] ☆ Formerly COM211
ACOM222A	COM222	COMPUTER STUDIES 2	2	SPR	BOSSIEUX Eric	1·2·3·4	(A) (L)[40] ☆ Formerly COM213
ACOM222B	COM222	COMPUTER STUDIES 2	2	AUT	BOSSIEUX Eric	1·2·3·4	(A) (L)[40] ☆ Formerly COM213
ACOM223A	COM223	COMPUTER STUDIES 3	2	AUT	BOSSIEUX Eric	1·2·3·4	(A) (L)[40] ☆ Formerly COM214
AENV1310	ENV131	ENVIRONMENTAL ISSUES 1	4	AUT	CAVASIN Nathalie	1·2·3·4	(A)
AGEO2010	GEO201	HUMAN GEOGRAPHY	4	AUT	CAVASIN Nathalie	1·2·3·4	(A)
AGEO2020	GEO202	GEOGRAPHY	4	SPR	CAVASIN Nathalie	1·2·3·4	(A)
ALNG2100	LNG210	INTRODUCTION TO LINGUISTICS	4	SPR	MOTOHASHI Tatsushi	1·2·3·4	(A)
AMTH1010	MTH101	COLLEGE MATHEMATICS	4	SPR	MURAKAMI Junko	1·2·3·4	(A)
AMTH1111	MTH111	MATHEMATICS AND STATISTICS FOR BUSINESS AND ECONOMICS	4	SPR	MURAKAMI Junko	1·2·3·4	(A) (L)[48]
AMTH1112	MTH111	MATHEMATICS AND STATISTICS FOR BUSINESS AND ECONOMICS	4	AUT	HASEBE Takuya	1·2·3·4	(L)[60]

#### SPECIALIZED EDUCATION

##### FLA CORE PROGRAM

AENG001A	ENG001	BASIC SKILLS(WRITING)	2	SPR	STAFF	1	
AENG1101	ENG110	ACADEMIC ENGLISH SKILLS	4	AUT	OKADA Hanako	1	
AENG1102	ENG110	ACADEMIC ENGLISH SKILLS	4	AUT	FOGAL Gary	1	
AENG110A	ENG110	ACADEMIC ENGLISH SKILLS	4	SPR	OKADA Hanako	1	
AENG110B	ENG110	ACADEMIC ENGLISH SKILLS	4	SPR	OKADA Hanako	1	
AENG1111	ENG111	ENGLISH COMPOSITION 1	4	AUT	TANAKA Akiko	1	(A)
AENG1112	ENG111	ENGLISH COMPOSITION 1	4	AUT	MARINA Olga	1	(A)
AENG1113	ENG111	ENGLISH COMPOSITION 1	4	AUT	MARINA Olga	1	(A)
AENG1114	ENG111	ENGLISH COMPOSITION 1	4	AUT	DINGLASAN Arlene	1	(A)
AENG1115	ENG111	ENGLISH COMPOSITION 1	4	AUT	TANAKA Akiko	1	(A)
AENG1116	ENG111	ENGLISH COMPOSITION 1	4	AUT	STAFF	1	
AENG111A	ENG111	ENGLISH COMPOSITION 1	4	SPR	DINGLASAN Arlene	1	(A)
AENG111B	ENG111	ENGLISH COMPOSITION 1	4	SPR	MARINA Olga	1	(A)
AENG111C	ENG111	ENGLISH COMPOSITION 1	4	SPR	TANAKA Akiko	1	(A)
AENG111D	ENG111	ENGLISH COMPOSITION 1	4	SPR	TANAKA Akiko	1	(A)
AENG111E	ENG111	ENGLISH COMPOSITION 1	4	SPR	MARINA Olga	1	(A)
AENG1121	ENG112	ENGLISH COMPOSITION 2	4	AUT	HEAGNEY Brian	1	(A)
AENG1122	ENG112	ENGLISH COMPOSITION 2	4	AUT	URUSHIHARA-Urvil Nobue	1	(A)
AENG1123	ENG112	ENGLISH COMPOSITION 2	4	AUT	URUSHIHARA-Urvil Nobue	1	(A)
AENG1124	ENG112	ENGLISH COMPOSITION 2	4	AUT	GOMAN Edward	1	(A)
AENG1125	ENG112	ENGLISH COMPOSITION 2	4	AUT	GOMAN Edward	1	(A)
AENG112A	ENG112	ENGLISH COMPOSITION 2	4	SPR	URUSHIHARA-Urvil Nobue	1	(A)
AENG112B	ENG112	ENGLISH COMPOSITION 2	4	SPR	GOMAN Edward	1	(A)

Registration CD	Course CD	Course Title	Cr.	Semester Offered	Instructor	Student Year	Remarks
AENG112C	ENG112	ENGLISH COMPOSITION 2	4	SPR	TANAKA Akiko	1	(A)
AENG112D	ENG112	ENGLISH COMPOSITION 2	4	SPR	URUSHIHARA-Urvil Nobue	1	(A)
AENG112E	ENG112	ENGLISH COMPOSITION 2	4	SPR	GOMAN Edward	1	(A)
AENG112F	ENG112	ENGLISH COMPOSITION 2	4	SPR	HEAGNEY Brian	1	(A)
AENG1151	ENG115	PUBLIC SPEAKING	4	AUT	GRIFFITHS David	2	(A)
AENG1152	ENG115	PUBLIC SPEAKING	4	AUT	OKADA Hanako	2	(A)
AENG1153	ENG115	PUBLIC SPEAKING	4	AUT	GRIFFITHS David	2	(A)
AENG1154	ENG115	PUBLIC SPEAKING	4	AUT	HEAGNEY Brian	2	(A)
AENG1155	ENG115	PUBLIC SPEAKING	4	AUT	FOGAL Gary	2	(A)
AENG1156	ENG115	PUBLIC SPEAKING	4	AUT	KUWAYAMA Shunsuke	2	(A)
AENG115A	ENG115	PUBLIC SPEAKING	4	SPR	OKADA Hanako	2	(A)
AENG115B	ENG115	PUBLIC SPEAKING	4	SPR	GRIFFITHS David	2	(A)
AENG115C	ENG115	PUBLIC SPEAKING	4	SPR	KUWAYAMA Shunsuke	2	(A)
AENG115D	ENG115	PUBLIC SPEAKING	4	SPR	GRIFFITHS David	2	(A)
AENG115E	ENG115	PUBLIC SPEAKING	4	SPR	HEAGNEY Brian	2	(A)
AENG115F	ENG115	PUBLIC SPEAKING	4	SPR	FOGAL Gary	2	(A)
ATHP1011	THP101	THINKING PROCESSES	4	AUT	CHOO Kukhee	1	(A)
ATHP1012	THP101	THINKING PROCESSES	4	AUT	STAFF	1	(A)
ATHP1013	THP101	THINKING PROCESSES	4	AUT	THOMPSON Mathew	1	(A)
ATHP1014	THP101	THINKING PROCESSES	4	AUT	STAFF	1	(A)
ATHP1015	THP101	THINKING PROCESSES	4	AUT	WITMER Robert	1	(A)
ATHP101A	THP101	THINKING PROCESSES	4	SPR	STRECHER Matthew	1	(A)
ATHP101B	THP101	THINKING PROCESSES	4	SPR	FOGAL Gary	1	(A)
ATHP101C	THP101	THINKING PROCESSES	4	AUT	STAFF	1	(A)
ATHP101D	THP101	THINKING PROCESSES	4	SPR	WITMER Robert	1	(A)
ATHP101E	THP101	THINKING PROCESSES	4	SPR	WITMER Robert	1	(A)
ATHP101F	THP101	THINKING PROCESSES	4	SPR	FOGAL Gary	1	(A)

## COMPARATIVE CULTURE

AART2010	ART201	INTRODUCTION TO ART HISTORY / VISUAL CULTURE 1	4	AUT	HIRASAWA Caroline	1·2·3	(A)
AART2500	ART250	INTRODUCTION TO ART HISTORY/VISUAL CULTURE 2	4	SPR	HIRASAWA Caroline	1·2·3	(A)
AART3010	ART301	SURVEY OF WESTERN ART 1	4		HAYASHI Michio	2·3·4	(A)
AART3020	ART302	SURVEY OF WESTERN ART 2	4		HAYASHI Michio	2·3·4	(A)
AART3210	ART321	SURVEY OF JAPANESE ART 1	4		HIRASAWA Caroline	2·3·4	(A)
AART3030	ART303	TOPICS IN JAPANESE ART	4	SPR	HIRASAWA Caroline	2·3·4	(A)☆Formerly ART322
AART3040	ART304	POPULAR CULTURE STUDIES	4		CHOO Kukhee	2·3·4	(A)
AART3510	ART351	STUDIES IN ART HISTORY	4		HAYASHI Michio	2·3·4	(A)
AART3520	ART352	STUDIES IN VISUAL CULTURE	4	AUT	TAKII Naoko	2·3·4	(A)
AART3680	ART368	GENDER IN JAPANESE VISUAL CULTURE	4	SPR	MURAI Noriko	2·3·4	(A)☆Formerly ART375 &ART367
AART3710	ART371	JAPANESE ART IN CROSS-CULTURAL CONTEXT	4		MURAI Noriko	2·3·4	(A)
AART3760	ART376	STUDIES IN MODERN JAPANESE ART HISTORY	4		MURAI Noriko	2·3·4	(A)
AART3050	ART305	ANIMATION STUDIES	4	AUT	CHOO Kukhee	2·3·4	(A)
AART3060	ART306	MEDIA STUDIES	4	SPR	CHOO Kukhee	2·3·4	(A)
AART4100	ART410	REPRESENTATION OF BODY: RACE AND GENDER	4	AUT	CHOO Kukhee	3·4	(A)
AART4530	ART453	COMPARATIVE ART HISTORY	4		HIRASAWA Caroline	3·4	(A)
AART4610	ART461	SEMINAR IN ART HISTORY 1	4		HAYASHI Michio	3·4	(R)
AART4630	ART463	STUDIES IN EAST ASIAN VISUAL CULTURE	4	AUT	HIRASAWA Caroline	3·4	(A)
AART4010	ART401	FILM STUDIES	4		CHOO Kukhee	3·4	(A)☆Formerly ART464
AART4820	ART482	SEMINAR IN JAPANESE ART HISTORY	4	SPR	MURAI Noriko	3·4	(R)
ALIT2010	LIT201	LITERARY GENRES	4	AUT	KONO Shion	1·2·3	(A)
ALIT2310	LIT231	INTRODUCTION TO JAPANESE LITERATURE	4	SPR	YIU Angela	1·2·3	(A)
ALIT3000	LIT300	WESTERN LITERATURE	4		KONO Shion	2·3·4	(A)
ALIT3040	LIT304	JAPANESE FILM	4		STRECHER Matthew	2·3·4	(A)
ALIT3070	LIT307	CONTEMPORARY JAPANESE LITERATURE	4	AUT	STRECHER Matthew	2·3·4	(A)
ALIT3090	LIT309	MODERN JAPAN THROUGH LITERATURE FILM AND MEDIA	4	AUT	SMITH Jordan	2·3·4	(A)
ALIT3100	LIT310	DRAMATIC AND PERFORMING ARTS IN JAPAN AND THE WORLD	4	SPR	FUJIKURA Takeo	2·3·4	(A)
ALIT3200	LIT320	AMERICAN POETRY	4	AUT	WITMER Robert	2·3·4	(A)
ALIT3220	LIT322	CONTEMPORARY LITERATURE	4	SPR	STRECHER Matthew	2·3·4	(A)
ALIT3240	LIT324	LITERATURE AND FILM	4	AUT	KONO Shion	2·3·4	(A)
ALIT3250	LIT325	ASIAN TEXTS: LEGACY OF THE PAST	4		THOMPSON Mathew	2·3·4	(A)
ALIT3310	LIT331	SURVEY OF JAPANESE LITERATURE 1	4	SPR	THOMPSON Mathew	2·3·4	(A)
ALIT3370	LIT337	MODERN JAPANESE FICTION	4	AUT	YIU Angela	2·3·4	(A)
ALIT3440	LIT344	COMPARATIVE LITERATURE	4	AUT	REDLICH Jeremy	2·3·4	(A)
ALIT3080	LIT308	REMEMBERING THE WAR IN JAPANESE LITERATURE	4	SPR	YIU Angela	2·3·4	(A)☆Formerly LIT455
ALIT3470	LIT347	ASIAN LITERATURE	4		YIU Angela	2·3·4	(A)
ALIT3520	LIT352	WORLD LITERATURE: A LITERARY JOURNEY	4		KONO Shion	2·3·4	(A)

Registration CD	Course CD	Course Title	Cr.	Semester Offered	Instructor	Student Year	Remarks
ALIT3530	LIT353	WRITING ABOUT LOVE: PAST AND PRESENT	4	SPR	THOMPSON Mathew	2·3·4	①
ALIT3700	LIT370	CREATIVE WRITING	4		WITMER Robert	2·3·4	①
ALIT4040	LIT404	HISTORY OF POPULAR LITERATURE IN JAPAN	4		STRECHER Matthew	3·4	①
ALIT4450	LIT445	SAMURAI IN LITERATURE AND HISTORY	4	AUT	THOMPSON Mathew	3·4	①
ALIT4050	LIT405	SEMINAR IN MODERN LITERATURE	4		YIU Angela	3·4	① ②
ALIT4700	LIT470	SEMINAR IN WORLD LITERATURE	4	SPR	KONO Shion	3·4	①
ARPH2010	RPH201	INTRODUCTION TO PHILOSOPHY	4	AUT	DROTT Edward	1·2·3	
ARPH2020	RPH202	FUNDAMENTALS OF RELIGION	4	SPR	MURAKAMI Tatsuo	1·2·3	
ARPH3010	RPH301	INTELLECTUAL TRADITIONS OF SOUTH ASIA	4	AUT	STAFF	2·3·4	①
ARPH3030	RPH303	THE ENCOUNTER OF RELIGIONS IN THE MODERN WORLD	4		MURAKAMI Tatsuo	2·3·4	①
ARPH3350	RPH335	RELIGION, CONFLICT AND VIOLENCE	4	AUT	MURAKAMI Tatsuo	2·3·4	
ARPH3410	RPH341	JAPANESE RELIGIONS	4	AUT	DROTT Edward	2·3·4	
ARPH3510	RPH351	RELIGION AND THE ARTS	4		STAFF	2·3·4	
ARPH3610	RPH361	BUDDHIST TRADITIONS	4	SPR	DROTT Edward	2·3·4	
ARPH3700	RPH370	BUSINESS ETHICS	4		ROBOUAM Thierry	2·3·4	
ARPH4010	RPH401	INDIGENOUS RELIGION	4	SPR	MURAKAMI Tatsuo	3·4	
ARPH4020	RPH402	SOUTH ASIAN CLASSICAL AND MEDIEVAL TEXTS	4	AUT	STAFF	3·4	
ARPH4110	RPH411	RELIGION AND THE BODY	4	SPR	DROTT Edward	3·4	①
ARPH4370	RPH437	PHILOSOPHICAL APPROACHES TO BUDDHISM	4		ROBOUAM Thierry	3·4	
ARPH4550	RPH455	SACRED SPACE AND TIME	4		STAFF	3·4	①

**INTERNATIONAL BUSINESS AND ECONOMICS**

AIBE2001	IBE200	PRINCIPLES OF MICROECONOMICS	4	SPR	OKABE Tomohito	1·2·3	①
AIBE2002	IBE200	PRINCIPLES OF MICROECONOMICS	4	AUT	KONISHI Yoshifumi	1·2·3	
AIBE2011	IBE201	PRINCIPLES OF MACROECONOMICS	4	SPR	KOSAKA Michiru	1·2·3	
AIBE2012	IBE201	PRINCIPLES OF MACROECONOMICS	4	AUT	ISAKA Naoto	1·2·3	
AIBE3000	IBE300	PRINCIPLES OF MANAGEMENT	4	SPR	HAGHIRIAN Parissa	2·3·4	
AIBE3030	IBE303	MANAGEMENT INFORMATION SYSTEMS	4	SPR	SINGH Mahendra	2·3·4	①
AIBE3050	IBE305	INTRODUCTION TO ACCOUNTING	4	AUT	UENISHI Junko	2·3·4	
AIBE3060	IBE306	MANAGEMENT ACCOUNTING	4	SPR	UENISHI Junko	2·3·4	
AIBE3100	IBE310	FINANCIAL MANAGEMENT	4	SPR	ISAKA Naoto	2·3·4	
AIBE3110	IBE311	INTERMEDIATE MICROECONOMICS	4	AUT	ASANO Akihito	2·3·4	
AIBE3130	IBE313	STRATEGIC MANAGEMENT	4	AUT	KHOJASTEY Yacob	2·3·4	
AIBE3150	IBE315	MARKETING	4	SPR	HORIUCHI Yoshihide	2·3·4	①
AIBE3160	IBE316	PUBLIC ECONOMICS	4		KONISHI Yoshifumi	2·3·4	
AIBE3200	IBE320	HUMAN RESOURCE MANAGEMENT	4	AUT	HAGHIRIAN Parissa	2·3·4	
AIBE3220	IBE322	INTERNATIONAL TRADE	4		ASANO Akihito	2·3·4	
AIBE3230	IBE323	INTERNATIONAL FINANCE	4		KOSAKA Michiru	2·3·4	
AIBE3260	IBE326	MONEY AND BANKING	4	SPR	ISAKA Naoto	2·3·4	
AIBE3310	IBE331	INDUSTRIAL ORGANIZATION	4	AUT	KONISHI Yoshifumi	2·3·4	
AIBE3320	IBE332	WOMEN AND MEN IN THE LABOR MARKET	4	AUT	HASEBE Takuya	2·3·4	
AIBE3400	IBE340	ECONOMIC STATISTICS	4	SPR	HASEBE Takuya	2·3·4	①[40]
AIBE3450	IBE345	NGO MANAGEMENT	4		STAFF	2·3·4	
AIBE3510	IBE351	INTERNATIONAL MARKETING	4	AUT	HORIUCHI Yoshihide	2·3·4	①
AIBE3530	IBE353	INTERNATIONAL BUSINESS	4	SPR	KHOJASTEY Yacob	2·3·4	
AIBE3560	IBE356	CONSUMER BEHAVIOR	4	AUT	STAFF	2·3·4	①
AIBE4010	IBE401	TOPICS IN JAPANESE BUSINESS AND ECONOMICS	4	SPR	TACHIKI Dennis	3·4	①
AIBE4050	IBE405	QUANTITATIVE APPROACHES TO MANAGEMENT	4	AUT	KHOJASTEY Yacob	3·4	①[40]
AIBE4300	IBE430	ECONOMIC SURVEY OF CONTEMPORARY JAPAN	4		KOSAKA Michiru	3·4	
AIBE4340	IBE434	ADVANCED MACROECONOMICS	4		KOSAKA Michiru	3·4	①
AIBE4350	IBE435	SEMINAR IN BUSINESS	4		HAGHIRIAN Parissa	3·4	①
AIBE4450	IBE445	MANAGEMENT IN JAPAN	4	SPR	HAGHIRIAN Parissa	3·4	
AIBE4550	IBE455	HUMAN RESOURCE MANAGEMENT IN JAPAN	4	SPR	DEBROUX Philippe	3·4	①
AIBE4570	IBE457	VENTURE MANAGEMENT	4	AUT	LIU Simon	3·4	①
AIBE4580	IBE458	OPERATIONS MANAGEMENT	4	SPR	KHOJASTEY Yacob	3·4	☆Formerly IBE456
AIBE4620	IBE462	ECONOMICS OF NATURAL RESOURCES AND ENVIRONMENT	4		KONISHI Yoshifumi	3·4	①
AIBE4640	IBE464	ADVERTISING	4		STAFF	3·4	①(A)
AIBE4710	IBE471	ECONOMICS OF HEALTH AND HEALTH CARE POLICY	4		HASEBE Takuya	3·4	①
AIBE4770	IBE477	STRATEGIC THINKING	4	AUT	ASANO Akihito	3·4	①
AIBE4860	IBE486	TOPICS IN FINANCE	4	AUT	ISAKA Naoto	3·4	①[40]
AIBE4910	IBE491	ISSUES IN ACCOUNTING	4	SPR	UENISHI Junko	3·4	①
AIBE4920	IBE492	FINANCIAL ACCOUNTING	4	AUT	UENISHI Junko	3·4	
EEC55300	407404	ECONOMETRICS 1	2	SPR	STAFF	2·3·4	E ①
EEC55400	407405	ECONOMETRICS 2	2	AUT	STAFF	2·3·4	E ①
EEC62100	467920	ASIAN ECONOMY 1	2	SPR	PUTHENKALAM John Joseph	2·3·4	E ①
EEC62200	467921	ASIAN ECONOMY 2	2	AUT	PUTHENKALAM John Joseph	2·3·4	E ①
EMG53600	430801	LOGISTICS	4		STAFF	2·3·4	①E ①
EMG53400	433300	DIRECT MARKETING	2		ARAI Noriko	2·3·4	E ①[200] ①
EMG54200	438410	AUDITING 1	2	SPR	MACHIDA Yoshihiro	2·3·4	(A) E ①
EMG54210	438420	AUDITING 2	2	AUT	MACHIDA Yoshihiro	2·3·4	(A) E ①

Registration CD	Course CD	Course Title	Cr.	Semester Offered	Instructor	Student Year	Remarks
<b>SOCIAL STUDIES</b>							
AANT2020	ANT202	INTRODUCTION TO CULTURAL AND SOCIAL ANTHROPOLOGY	4	AUT	FAHY Sandra	1·2·3	
AANT2200	ANT220	ANTHROPOLOGY OF JAPAN	4	AUT	SLATER David	1·2·3	
AANT2300	ANT230	CULTURE AND IDENTITY	4	SPR	WATANABE Takehiro	1·2·3	
AANT3030	ANT303	JAPANESE POPULAR CULTURE	4	SPR	GALBRAITH Patrick	2·3·4	(A)
AANT3090	ANT309	JAPAN RESEARCH	4		SLATER David	2·3·4	(1)
AANT3100	ANT310	RESEARCH METHODS IN ANTHROPOLOGY	4	SPR	FAHY Sandra	2·3·4	
AANT3170	ANT317	FIELD METHODS IN CULTURAL ANTHROPOLOGY	4		WATANABE Takehiro	2·3·4	(1)
AANT3180	ANT318	DIGITAL ORAL NARRATIVES 1	4		SLATER David	2·3·4	(1)☆Formerly ANT315
AANT3190	ANT319	DIGITAL ORAL NARRATIVES 2	4	AUT	SLATER David	2·3·4	(1)☆Formerly ANT316
AANT3630	ANT363	ANTHROPOLOGY AND MODERN SOCIETY	4	SPR	NOZAWA Shunsuke	2·3·4	(A)
AANT3650	ANT365	KOREAN STUDIES: NORTH AND SOUTH	4	AUT	FAHY Sandra	2·3·4	(1)
AANT3020	ANT302	HUMAN ECOLOGY: RIVERS 1	2	SPR	WATANABE Takehiro	2·3·4	(X)
AANT4470	ANT447	ANTHROPOLOGY PRACTICUM 1	4	SPR	SLATER David	3·4	(1)⊙
AANT4480	ANT448	ANTHROPOLOGY PRACTICUM 2	4		SLATER David	3·4	(1)⊙
AANT4610	ANT461	NATURE AND SOCIETY	4	AUT	WATANABE Takehiro	3·4	⊙
AANT4620	ANT462	ADVANCED READINGS IN ANTHROPOLOGY	4	SPR	FAHY Sandra	3·4	⊙
ASOC2010	SOC201	INTRODUCTION TO SOCIOLOGY	4	SPR	WANK David	1·2·3	
ASOC2100	SOC210	INTRODUCTION TO SOCIAL THEORY	4	AUT	FARRER James	1·2·3	
ASOC2250	SOC225	INTRODUCTION TO JAPANESE SOCIETY	4	SPR	SUGAWARA Yuka	1·2·3	
ASOC3030	SOC303	BORDER CROSSING AND EAST ASIA	4	SPR	TOKUNAGA Tomoko	2·3·4	(A)
ASOC3100	SOC310	SOCIOLOGY OF CULTURE	4	SPR	FARRER James	2·3·4	(1)
ASOC3120	SOC312	INTRODUCTION TO FIELD RESEARCH	4		WANK David	2·3·4	
ASOC3150	SOC315	SURVEY METHODS	4	AUT	SUGAWARA Yuka	2·3·4	
ASOC3160	SOC316	QUALITATIVE RESEARCH METHODS	4	SPR	FARRER James	2·3·4	
ASOC3300	SOC330	SOCIETY AND POLITICS	4		WANK David	2·3·4	(1)
ASOC3370	SOC337	POPULATION AND SOCIETY	4	AUT	SUGAWARA Yuka	2·3·4	(1)
ASOC4010	SOC401	SOCIOLOGY OF HEALTH AND AGING	4	SPR	SUGAWARA Yuka	3·4	⊙ ☆Formerly SOC470
ASOC4390	SOC439	SOCIOLOGY OF SEXUALITY AND GENDER	4	AUT	FARRER James	3·4	⊙ ☆Formerly SOC339
ASOC4480	SOC448	SOCIOLOGY OF ECONOMIC LIFE	4	SPR	WANK David	3·4	⊙
AHST2510	HST251	DEVELOPMENT OF JAPANESE CIVILIZATION 1	4	AUT	GRAMLICH-OKA Bettina	1·2·3	
AHST2520	HST252	DEVELOPMENT OF JAPANESE CIVILIZATION 2	4	SPR	SAALER Sven	1·2·3	
AHST2610	HST261	HISTORY OF CHINESE CIVILIZATION	4	SPR	HESS Christian	1·2·3	
AHST3020	HST302	TOPICS IN HISTORY 1	4	SPR	GRAMLICH-OKA Bettina	2·3·4	(1)
AHST3030	HST303	TOPICS IN HISTORY 2	4		HESS Christian	2·3·4	(1)
AHST3520	HST352	WOMEN IN JAPANESE HISTORY	4	SPR	NAKAI Maki	2·3·4	(A)
AHST3530	HST353	MODERN JAPAN	4	AUT	SAALER Sven	2·3·4	
AHST3540	HST354	HISTORY OF JAPANESE FOREIGN RELATIONS	4		SAALER Sven	2·3·4	(1)
AHST3670	HST367	CHINESE CULTURAL HISTORY	4	AUT	HESS Christian	2·3·4	☆Formerly HST363
AHST3710	HST371	GLOBAL HISTORY	4	SPR	WEBER Torsten	2·3·4	(A)
AHST4450	HST445	RELIGION AND SOCIETY IN JAPAN	4	SPR	UMEZAWA Fumiko	3·4	(A)
AHST4530	HST453	SEMINAR IN MODERN JAPANESE HISTORY 1	4	SPR	UEDA Kiyoshi	3·4	(A)
AHST4540	HST454	SEMINAR IN JAPANESE HISTORY	4	AUT	NAKAI Maki	3·4	(A)
AHST4630	HST463	ISSUES IN CHINESE HISTORY	4	SPR	HESS Christian	3·4	(1)
AHST4650	HST465	SEMINAR IN MODERN EAST ASIAN HISTORY	4		HESS Christian	3·4	(1)
AHST4660	HST466	MODERN KOREAN HISTORY	4	AUT	CAPRIO Mark	3·4	(A) ☆Formerly HST365
AHST4710	HST471	THE EURO-ASIAN ENCOUNTER	4	SPR	BURTSCHER Michael	3·4	(A)
AHST4730	HST473	ISSUES IN EAST ASIAN HISTORY	4	AUT	BURTSCHER Michael	3·4	(A)
HHT54300	165814	CONFUCIAN ETHICS IN THE CHOSON ERA	2	AUT	YAMAUCHI Koichi	2·3·4	(R) H (1)
FES76700	501367	TOPICS IN AMERICAN HISTORY	2	AUT	OSHIO Kazuto	2·3·4	(1) F (R) (1)
APOL2010	POL201	THEORIES AND THEMES OF CONTEMPORARY POLITICS	4	AUT	NAKANO Koichi	1·2·3	
APOL2050	POL205	INTRODUCTION TO INTERNATIONAL RELATIONS	4	SPR	ANNO Tadashi	1·2·3	
APOL2100	POL210	INTRODUCTION TO COMPARATIVE POLITICS	4	AUT	ITO Takeshi	1·2·3	
APOL2150	POL215	CONTROVERSIES IN GLOBALIZATION	4	SPR	BURRETT Tina	1·2·3	
APOL3010	POL301	CLASSICAL WESTERN POLITICAL THEORY	4		NAKANO Koichi	2·3·4	(1)
APOL3030	POL303	JAPANESE FOREIGN AND SECURITY POLICY	4	SPR	ANNO Tadashi	2·3·4	☆Formerly POL376
APOL3040	POL304	HUMAN ECOLOGY: RIVERS 2	2	SPR	ITO Takeshi	2·3·4	(X)
APOL3050	POL305	MODERN WESTERN POLITICAL THEORY	4	AUT	NAKANO Koichi	2·3·4	(1)

Registration CD	Course CD	Course Title	Cr.	Semester Offered	Instructor	Student Year	Remarks
APOL3100	POL310	EUROPEAN POLITICS	4	AUT	BURRETT Tina	2•3•4	
APOL3160	POL316	NONPROFIT NGOS IN COMPARATIVE CONTEXTS	4	AUT	ROSSITTO Sarajejan	2•3•4	(A)
APOL3210	POL321	JAPANESE GOVERNMENT AND POLITICS	4	SPR	NAKANO Koichi	2•3•4	
APOL3410	POL341	SOUTHEAST ASIAN POLITICS	4	SPR	STAFF	2•3•4	(A)
APOL3540	POL354	GLOBAL POLITICAL ECONOMY	4		BURRETT Tina	2•3•4	(I)
APOL3550	POL355	ENVIRONMENTAL POLITICS OF AGRICULTURE	4	AUT	ITO Takeshi	2•3•4	(I)
APOL4050	POL405	SEMINAR IN POLITICAL SCIENCE	4	AUT	MCNEILL David	3•4	(A)
APOL4070	POL407	AGRARIAN SOCIETIES	4		ITO Takeshi	3•4	(I)
APOL4080	POL408	POLITICAL LEADERSHIP	4	SPR	BURRETT Tina	3•4	(I)
APOL4140	POL414	NATIONALISM, CITIZENSHIP AND DEMOCRACY IN JAPAN	4		ANNO Tadashi	3•4	(I)
APOL4220	POL422	COMPARATIVE POLITICS OF ADVANCED INDUSTRIAL	4		NAKANO Koichi	3•4	(I)
APOL4270	POL427	INTERNATIONAL RELATIONS THEORY	4	AUT	ANNO Tadashi	3•4	(I)
APOL4290	POL429	INTERNATIONAL AND REGIONAL ORGANIZATIONS	4	AUT	BURRETT Tina	3•4	(I)
APOL4410	POL441	POLITICAL ECONOMY OF DEVELOPMENT	4		ITO Takeshi	3•4	(I)
APOL4600	POL460	COMPARATIVE POLITICS OF POST-COMMUNIST STATES	4		ANNO Tadashi	3•4	(I)
BGS57602	BGS57602	SEMINAR (GLOBAL & INTERNATIONAL STUDIES)1	2	SPR	WESSELS David	3•4	G (R) (I)
BGS57603	BGS57603	SEMINAR (GLOBAL & INTERNATIONAL STUDIES)2	2	AUT	WESSELS David	3•4	G (R) (I)
BGS52400	BGS5240	FOREIGN POLICY 1	2	SPR	HIWATARI Yumi	3•4	G (I) [1901] (I)
BGS52401	BGS5240	FOREIGN POLICY 2	2	AUT	HIWATARI Yumi	3•4	G (I) [1901] (I)
<b>LINGUISTICS</b>							
ALNG3010	LNG301	INTRODUCTION TO JAPANESE	4	AUT	MOTOHASHI Tatsushi	2•3•4	
ALNG3020	LNG302	HISTORY OF THE JAPANESE LANGUAGE	4	SPR	MOTOHASHI Tatsushi	2•3•4	
ALNG4520	LNG452	TOPICS IN LINGUISTICS	4	AUT	MOTOHASHI Tatsushi	3•4	

## § b320 CHANGES IN COURSE TITLE

Courses listed here under a new title may not be taken if they were taken previously under the former title.

NEW COURSE NUMBER & TITLE			FORMER COURSE NUMBER & TITLE	
		year changed		
ANT202	INTRODUCTION TO CULTURAL AND SOCIAL ANTHROPOLOGY	2014	ANT202	CULTURAL & SOCIAL ANTHROPOLOGY
ANT341	TOPICS IN ANTHROPOLOGY	2013	ANT341	GENDER AND SOCIETIES
ANT447	ANTHROPOLOGY PRACTICUM 1	2012	ANT447	ANTHROPOLOGY PRACTICUM
ANT461	NATURE AND SOCIETY	2014	ANT461	SEMINAR IN ANTHROPOLOGY
ART201	INTRODUCTION TO ART HISTORY/VISUAL CULTURE 1	2014	ART201	INTRODUCTION TO ART HISTORY
ART250	INTRODUCTION TO ART HISTORY/VISUAL CULTURE 2	2014	ART250	INTRODUCTION TO JAPANESE ART
ART352	STUDIES IN VISUAL CULTURE	2014	ART352	HST AND THEORY OF ARCHITECTURE
ART482	SEMINAR IN JAPANESE ART HISTORY	2012	ART482	JAPANESE NARRATIVE PAINTING
HST261	HISTORY OF CHINESE CIVILIZATION	2014	HST261	HISTORY OF CHINESE CIVIL 1
HST352	WOMEN IN JAPANESE HISTORY	2014	HST352	JAPANESE WOMEN'S HISTORY
HST463	ISSUES IN CHINESE HISTORY	2012	HST463	ISSUES IN CHINESE WOMEN'S HIST
HST465	SEMINARS IN MODERN EAST ASIAN HISTORY	2013	HST465	SEMINARS IN EAST ASIAN ECONOMIC HISTORY
HST471	THE EURO-ASIAN ENCOUNTER	2014	HST471	THE EURO POWERS & EAST ASIA
IBE200	PRINC OF MICROECONOMICS	2012	IBE200	PRINC OF ECONOMICS (MICRO)
IBE201	PRINC OF MACROECONOMICS	2012	IBE201	PRINC OF ECONOMICS (MACRO)
IBE311	INTERMEDIATE MICROECONOMICS	2012	IBE311	INTERMEDIATE MICRO
IBE455	HUMAN RESOURCE MANAGEMENT IN JAPAN	2012	IBE455	HUMAN RESOURCE DEVELOP IN JAPN
POL201	THEORIES AND THEMES OF CONTEMPORARY POLITICS	2012	POL201	INTRO TO METHODS IN POL SCI
POL354	GLOBAL POLITICAL ECONOMY	2014	POL354	INT'L POLITICAL ECONOMY
POL355	ENVIRONMENTAL POLITICS OF AGRICULTURE	2014	POL355	ENVIRONMENT POLITICS OF AGRICULTURE
POL376	REGIONAL SECURITY IN NORTHEAST ASIA	2012	POL376	SECURITY IN NORTHEAST ASIA
POL429	INTERNATIONAL AND REGIONAL ORGANISATIONS	2014	POL429	INT'L ORGANIZATION AND LAW
POL460	COMPARATIVE POLITICS OF POST-COMMUNIST STATES	2014	POL460	COMP POL POST COMMUNIST STATES
RPH302	CONTEMPORARY ISSUES IN RELIGION AND SOCIETY	2012	RPH302	WESTERN TRAD.AND MOD.WORLD 1
RPH303	THE ENCOUNTER OF RELIGIONS IN THE MODERN WORLD	2012	RPH303	WESTERN TRAD.AND MOD.WORLD 2
RPH351	RELIGION AND THE ARTS	2012	RPH351	RELIGION AND THE ARTS 1
RPH352	JAPANESE RELIGION AND THE ARTS	2012	RPH352	RELIGION AND THE ARTS 2

**§ b330 LANGUAGE COURSES (Except Japanese)**  
**OFFERED BY THE CENTER FOR LANGUAGE EDUCATION AND RESEARCH**

Registration CD	Course CD	Course Title	Cr.	Semester Offered	Instructor	Student Year	Remarks
ACHN1011	CHN101	BASIC CHINESE 1	2	SPR	ZHANG Tong/FEI Yan*	1•2	[30]
ACHN1012	CHN101	BASIC CHINESE 1	2	AUT	ZHANG Tong/FEI Yan*	1•2	[30]
ACHN1021	CHN102	BASIC CHINESE 2	2	SPR	ZHANG Tong/FEI Yan*	1•2	[30]
ACHN1022	CHN102	BASIC CHINESE 2	2	AUT	ZHANG Tong/FEI Yan*	1•2	[30]
ACHN1031	CHN103	INTERMEDIATE CHINESE 1	2	SPR	HUANG Wanting/LIAN Hong*	1•2	[30]
ACHN1032	CHN103	INTERMEDIATE CHINESE 1	2	AUT	HUANG Wanting/LIAN Hong*	1•2	[30]
ACHN1041	CHN104	INTERMEDIATE CHINESE 2	2	SPR	HUANG Wanting/LIAN Hong*	1•2	[30]
ACHN1042	CHN104	INTERMEDIATE CHINESE 2	2	AUT	HUANG Wanting/LIAN Hong*	1•2	[30]
AFRN101A	FRN101	BASIC FRENCH 1	2	SPR	KITAMURA Ayako/LOPEZ Emmanuel*	1•2	A class, [30]
AFRN101B	FRN101	BASIC FRENCH 1	2	SPR	DELMARE Gilles*	1•2	B class, [30]
AFRN1012	FRN101	BASIC FRENCH 1	2	AUT	DURRENBERGER Vincent/PIRIOU Vincent*	1•2	[30]
AFRN1021	FRN102	BASIC FRENCH 2	2	SPR	DELMARE Gilles*	1•2	
AFRN102A	FRN102	BASIC FRENCH 2	2	AUT	KITAMURA Ayako/LOPEZ Emmanuel*	1•2	A class, [30]
AFRN102B	FRN102	BASIC FRENCH 2	2	AUT	DURRENBERGER Vincent/PIRIOU Vincent*	1•2	B class, [30]
AFRN103A	FRN103	INTERMEDIATE FRENCH 1	2	SPR	COHEN Jacqueline*	1•2	A class, [30]
AFRN103B	FRN103	INTERMEDIATE FRENCH 1	2	SPR	DURRENBERGER Vincent/PIRIOU Vincent*	1•2	B class, [30]
AFRN1032	FRN103	INTERMEDIATE FRENCH 1	2	AUT	DELMARE Gilles*	1•2	
AFRN1041	FRN104	INTERMEDIATE FRENCH 2	2	SPR	DURRENBERGER Vincent/PIRIOU Vincent*	1•2	
AFRN104A	FRN104	INTERMEDIATE FRENCH 2	2	AUT	COHEN Jacqueline*	1•2	A class, [30]
AFRN104B	FRN104	INTERMEDIATE FRENCH 2	2	AUT	DELMARE Gilles*	1•2	B class, [30]
AFRN2010	FRN201	ADVANCED FRENCH 1	2	SPR	DURRENBERGER Vincent/GAILLARD Nicolas*	1•2	
AFRN2020	FRN202	ADVANCED FRENCH 2	2	AUT	DURRENBERGER Vincent/GAILLARD Nicolas*	1•2	
ASPN1011	SPN101	BASIC SPANISH 1	2	SPR	MARTÍNEZ Jesús	1•2	[30]
ASPN101A	SPN101	BASIC SPANISH 1	2	AUT	MARTÍNEZ Jesús/DE ARCOS PASTOR Angustias*	1•2	A class, [30]
ASPN101B	SPN101	BASIC SPANISH 1	2	AUT	HIROYASU Yoshimi/SHINTANI Roxana*	1•2	B class, [30]
ASPN102A	SPN102	BASIC SPANISH 2	2	SPR	KASHIWAGI Noriko*/DE ARCOS PASTOR Angustias*	1•2	A class, [30]
ASPN102B	SPN102	BASIC SPANISH 2	2	SPR	ISABEL GALA Carlos*/TAKAYAMA Patricia*	1•2	B class, [30]
ASPN1022	SPN102	BASIC SPANISH 2	2	AUT	MARTÍNEZ Jesús	1•2	
ASPN1031	SPN103	INTERMEDIATE SPANISH 1	2	SPR	HIROYASU Yoshimi/FOWLER Arthur*	1•2	
ASPN103A	SPN103	INTERMEDIATE SPANISH 1	2	AUT	KASHIWAGI Noriko*/DE ARCOS PASTOR Angustias*	1•2	A class, [30]
ASPN103B	SPN103	INTERMEDIATE SPANISH 1	2	AUT	ISABEL GALA Carlos*/TAKAYAMA Patricia*	1•2	B class, [30]
ASPN104A	SPN104	INTERMEDIATE SPANISH 2	2	SPR	MARTÍNEZ Jesús/DE ARCOS PASTOR Angustias*	1•2	A class, [30]
ASPN104B	SPN104	INTERMEDIATE SPANISH 2	2	SPR	HIROYASU Yoshimi/SHINTANI Roxana*	1•2	B class, [30]
ASPN1042	SPN104	INTERMEDIATE SPANISH 2	2	AUT	HIROYASU Yoshimi/FOWLER Arthur*	1•2	
ASPN2010	SPN201	ADVANCED SPANISH 1	2	SPR	NAKAJIMA Sayaka/MARTINEZ Jesus	1•2	
ASPN2020	SPN202	ADVANCED SPANISH 2	2	AUT	NAKAJIMA Sayaka/MARTINEZ Jesus	1•2	

[ ] = Lottery Course. Number in brackets is the capacity

Instructor's name with \* = adjunct instructor

For descriptions of the courses listed above, please refer to course syllabi on Loyola.



## § b340 JAPANESE LANGUAGE PROGRAM (JLP)

The FLA expects students to become Japanese/English bilinguals. The Center for Language Education and Research (CLER) offers multiple tracks and levels of Japanese language courses. The type of course a student initially enrolls in will depend on his/her language background. Placement into the JLP will be determined by a placement test. Students should consult the CLER about the Japanese Placement Test. Further information about the JLP can be found in the brochure “Japanese Language Program.”

### LANGUAGE COURSES (Japanese)

#### OFFERED BY THE CENTER FOR LANGUAGE EDUCATION AND RESEARCH

Registration CD	Course CD	Course Title	Cr.	Semester Offered	Instructor	Student Year	Remarks
※1	JPN111	JAPANESE 1	4	SPR	STAFF	1•2•3•4	
※1	JPN111	JAPANESE 1	4	AUT	STAFF	1•2•3•4	
※1	JPN150	JAPANESE M1	4	SPR	STAFF	1•2•3•4	
※1	JPN150	JAPANESE M1	4	AUT	STAFF	1•2•3•4	
※1	JPN112	JAPANESE 2	4	SPR	STAFF	1•2•3•4	
※1	JPN112	JAPANESE 2	4	AUT	STAFF	1•2•3•4	
※1	JPN112	JAPANESE 2	4	※2	STAFF	1•2•3•4	
※1	JPN200	JAPANESE M2	4	SPR	STAFF	1•2•3•4	
※1	JPN200	JAPANESE M2	4	AUT	STAFF	1•2•3•4	
※1	JPN211	JAPANESE 3	4	SPR	STAFF	1•2•3•4	
※1	JPN211	JAPANESE 3	4	※2	STAFF	1•2•3•4	
※1	JPN211	JAPANESE 3	4	AUT	STAFF	1•2•3•4	
※1	JPN250	JAPANESE M3	4	SPR	STAFF	1•2•3•4	
※1	JPN250	JAPANESE M3	4	AUT	STAFF	1•2•3•4	
※1	JPN212	JAPANESE 4	4	SPR	STAFF	1•2•3•4	
※1	JPN212	JAPANESE 4	4	AUT	STAFF	1•2•3•4	
※1	JPN212	JAPANESE 4	4	※2	STAFF	1•2•3•4	
※1	JPN321	ADVANCED JAPANESE 1	4	SPR	STAFF	1•2•3•4	
※1	JPN321	ADVANCED JAPANESE 1	4	AUT	STAFF	1•2•3•4	
※1	JPN322	ADVANCED JAPANESE 2	4	SPR	STAFF	1•2•3•4	
※1	JPN322	ADVANCED JAPANESE 2	4	AUT	STAFF	1•2•3•4	
※1	JPN311	BUSINESS JAPANESE 1	2	SPR	STAFF	1•2•3•4	★
※1	JPN311	BUSINESS JAPANESE 1	2	AUT	STAFF	1•2•3•4	★
※1	JPN312	BUSINESS JAPANESE 2	2	SPR	STAFF	1•2•3•4	★
※1	JPN312	BUSINESS JAPANESE 2	2	AUT	STAFF	1•2•3•4	★
※1	JPN315	BUSINESS JAPANESE (PREPARATION FOR INTERNSHIP)	1	SPR/AUT	YONEZAWA Masako	1•2•3•4	★※4
※1	JPN180	INTENSIVE JAPANESE 1	8	SPR	STAFF	1•2•3•4	
※1	JPN180	INTENSIVE JAPANESE 1	8	AUT	STAFF	1•2•3•4	
※1	JPN270	INTENSIVE JAPANESE 2	8	SPR	STAFF	1•2•3•4	
※1	JPN270	INTENSIVE JAPANESE 2	8	AUT	STAFF	1•2•3•4	
※1	JPN280	INTENSIVE JAPANESE 3	8	SPR	STAFF	1•2•3•4	
※1	JPN280	INTENSIVE JAPANESE 3	8	AUT	STAFF	1•2•3•4	
※1	JPN370	INTENSIVE JAPANESE 4	8	SPR	STAFF	1•2•3•4	
※1	JPN370	INTENSIVE JAPANESE 4	8	AUT	STAFF	1•2•3•4	
AJPN340A	JPN340	READING & WRITING (BASICS)	2	SPR	STAFF	1•2•3•4	
AJPN340I	JPN340	READING & WRITING (BASICS)	2	AUT	STAFF	1•2•3•4	
AJPN341A	JPN341	READING & WRITING 1	2	SPR	STAFF	1•2•3•4	
AJPN341I	JPN341	READING & WRITING 1	2	AUT	STAFF	1•2•3•4	
AJPN342A	JPN342	READING & WRITING 2	2	SPR	STAFF	1•2•3•4	
AJPN342B	JPN342	READING & WRITING 2	2	SPR	STAFF	1•2•3•4	
AJPN342I	JPN342	READING & WRITING 2	2	AUT	STAFF	1•2•3•4	
AJPN343A	JPN343	READING & WRITING 3	2	SPR	STAFF	1•2•3•4	
AJPN343B	JPN343	READING & WRITING 3	2	SPR	STAFF	1•2•3•4	
AJPN343I	JPN343	READING & WRITING 3	2	AUT	STAFF	1•2•3•4	
AJPN343I	JPN343	READING & WRITING 3	2	AUT	STAFF	1•2•3•4	
AJPN349A	JPN349	JAPANESE LITERACY 1	2	SPR	STAFF	1•2•3•4	※3
AJPN349B	JPN349	JAPANESE LITERACY 1	2	SPR	STAFF	1•2•3•4	※3
AJPN349I	JPN349	JAPANESE LITERACY 1	2	AUT	STAFF	1•2•3•4	※3
AJPN349I	JPN349	JAPANESE LITERACY 1	2	AUT	STAFF	1•2•3•4	※3

Registration CD	Course CD	Course Title	Cr.	Semester Offered	Instructor	Student Year	Remarks
AJPN353A	JPN353	JAPANESE LITERACY 2	4	SPR	STAFF	1•2•3•4	★
AJPN353B	JPN353	JAPANESE LITERACY 2	4	SPR	STAFF	1•2•3•4	★
AJPN3531	JPN353	JAPANESE LITERACY 2	4	AUT	STAFF	1•2•3•4	★
AJPN3532	JPN353	JAPANESE LITERACY 2	4	AUT	STAFF	1•2•3•4	★
AJPN4050	JPN405	TRANS ENG TO JPN :THEORY&PRAC1	4	SPR	KATORI Yoshikazu*	1•2•3•4	★
AJPN4060	JPN406	TRANS ENG TO JPN :THEORY&PRAC2	4	AUT	KATORI Yoshikazu*	1•2•3•4	★
AJPN4071	JPN407	TRANS JPN TO ENG :THEORY&PRAC	4	SPR	TAKAHASHI Kinuko*	1•2•3•4	★
AJPN4072	JPN407	TRANS JPN TO ENG :THEORY&PRAC	4	AUT	TAKAHASHI Kinuko*	1•2•3•4	★
AJPN431A	JPN431	ACADEMIC JAPANESE 1-1	2	SPR	SATO Kimiko	1•2•3•4	★
AJPN431B	JPN431	ACADEMIC JAPANESE 1-1	2	SPR	SATO Kimiko	1•2•3•4	★
AJPN432A	JPN432	ACADEMIC JAPANESE 1-2	2	AUT	SATO Kimiko	1•2•3•4	★
AJPN432B	JPN432	ACADEMIC JAPANESE 1-2	2	AUT	SATO Kimiko	1•2•3•4	★
AJPN4410	JPN441	ACADEMIC JAPANESE 2-1	2	SPR	AIGASE Chigusa*	1•2•3•4	★※4
AJPN4420	JPN442	ACADEMIC JAPANESE 2-2	2	AUT	AIGASE Chigusa*	1•2•3•4	★※4
AJPN4450	JPN445	INTRODUCTION TO JAPANESE ECONOMIC STUDIES FOR INTERNATIONAL STUDENTS 1	2	SPR	SATO Kimiko, etc	1•2•3•4	★※4
AJPN4460	JPN446	INTRODUCTION TO JAPANESE ECONOMIC STUDIES FOR INTERNATIONAL STUDENTS 2	2	AUT	SATO Kimiko, etc	1•2•3•4	★※4

Instructor's name with \* = adjunct instructor

For descriptions of the courses listed above, please refer to course syllabi on Loyola.

★These courses can only be counted as SE Electives for the students who entered before 2016.

※1: Please see the JPT result and timetable on Loyola.

※2: These courses are mainly for students in Green Science and Green Engineering and to be offered in summer/spring vacation.

For the details, please see the brochure "Japanese Language Program."

※3: Available from AY2016 in place of JPN352

※4: Available from AY2017



## SECTION C : SOPHIA SHORT-TERM PROGRAMS & CERTIFICATE PROGRAMS

### § c100 SHORT-TERM PROGRAMS

Every year students and professionals from throughout the world come to attend Sophia Short Term Programs. The Summer Session in Asian Studies is organized by the Faculty of Liberal Arts.

#### § c101 SUMMER SESSION IN ASIAN STUDIES

Since its foundation in 1961, Sophia University's three-week Summer Session in Asian Studies has provided students with the opportunity to study about Japan and explore the country's relation with Asia and the rest of the world. Participants choose two intensive courses (6 credits) from a list including Japanese language, history, art, religion, literature, society, culture, economics, and politics.

**The Summer Session in Asian Studies will be held from July 20 to August 11, 2017.**

FLA students can register to the Summer Session in Asian Studies. Credit earned in the Summer Session in Asian Studies will be counted as Specialized Education Electives.

#### List of courses FLA students can count as Specialized Education Electives:

- ARZ320 Japanese Art (3cr)
- IBZ415 Contemporary Japanese Economy (3cr)
- IBZ435 Development Issues: Asia and the World (3cr)
- IBZ446 Japanese Business and Management (3cr)
- HSZ310 Japanese History: Edo and Tokyo (3cr)
- HSZ320 Topics in Japanese History (3cr)
- LIZ333 Japanese Literature and the City (3cr)
- LIZ440 Japanese Theater (3cr)
- POZ300 Contemporary Japanese Politics (3cr)
- RPZ330 Survey of Japanese Religions (3cr)
- SOZ420 Contemporary Chinese Society (3cr)
- SOZ430 Japanese Popular Culture (3cr)
- SOZ470 Contemporary Japanese Society (3cr)

For General information about the Summer Session in Asian Studies, please refer to the following webpage: [http://www.sophia.ac.jp/eng/admissions/summer/summer\\_asia](http://www.sophia.ac.jp/eng/admissions/summer/summer_asia)  
Syllabus and details of course registration procedure can be found on the Loyola web service.

## § c200 CERTIFICATE PROGRAMS

FLA students who wish to apply for one of the following certificates should submit their application in their last term. They will receive the certificate at the time of graduation.

### § c210 JAPANESE STUDIES CERTIFICATE

Only students who entered before 2015 are eligible to apply for this certificate.

Together with completing the requirements for a B.A. degree from FLA, students may combine GS, Major, and Specialized Elective courses to obtain a Certificate in Japanese Studies (日本研究履修証明). For the certificate they should complete six courses (24 credits) in designated Japanese Studies (JS) courses according to the following specifications.

JS courses are divided among two categories: A (Comparative Culture) and B (Social Studies and IBE). FLA students must take a combination of courses from both categories, with a maximum of four courses (16 credits) from a single category. At least three courses (12 credits) must be taken as SE electives.

Students from other faculties and non-degree students may obtain a Certificate in Japanese Studies by completing six courses (24 credits) in designated FLA JS courses. These students should take a combination of courses from categories A and B, with a maximum of four courses (16 credits) from a single category.

#### Category A (Comparative Culture)

ART250	Introduction to Art History/Visual Culture 2
ART321	Survey of Japanese Art 1
ART322	Survey of Japanese Art 2
ART361	Studies in Japanese Art History 1
ART365	Studies in Japanese Art History 2
ART375	Topics in Japanese Art History
ART368	Gendar in Japanese Visual Culture
ART451	Comparative Art History 1
ART452	Comparative Art History 2
ART453	Comparative Art History
ART482	Seminar in Japanese Art History
LIT231	Introduction to Japanese Literature
LIT331	Survey of Japanese Literature 1
LIT332	Survey of Japanese Literature 2
LIT365	Topics in Japanese Literature 1
LIT366	Topics in Japanese Literature 2

---

LIT337	Modern Japanese Fiction
LIT346	Topics in Modern Literature
LIT304	Japanese Film
LIT305	Japanese Popular Culture
LIT306	Time and Space in Japanese Literature
LIT455	War and Post War in Japanese Literature
LIT435	Modern Japanese Fiction 1
LIT436	Modern Japanese Fiction 2
LIT450	Contemporary Japanese Theater
RPH341	Japanese Religions
RPH351	Religion and the Arts
RPH352	Japanese Religion and The Arts
RPH361	Buddhist Traditions
RPH411	Religion and The Body
RPH414	Comparative Religion and Culture
RPH435	Symbol and Religion
RPH437	Philosophical Approaches to Buddhism
RPH455	Sacred Space and Time
RPH480	Christianity and Japanese Culture

#### **Category B (Social Studies and IBE)**

ANT220	Anthropology of Japan
ANT309	Japan Research
HST251	Development of Japanese Civilization 1
HST252	Development of Japanese Civilization 2
HST300	Topics in History
HST352	Japanese Women's History
HST353	Modern Japan
HST354	History of Japanese Foreign Relations
HST302	Topics in History 1
HST303	Topics in History 2
HST439	Issues in Japanese History and Thought
HST445	Religion and Society in Japan
HST453	Seminar in Modern Japanese History 1
HST454	Seminar in Japanese History
HST456	Seminar in Modern Japanese History 2
POL321	Japanese Government and Politics
POL414	Nationalism, Citizenship, and Democracy in Japan
POL422	Comparative Politics of Advanced Industrial Democracies
IBE430	Economic Survey of Contemporary Japan
IBE445	Management in Japan
IBE455	Human Resource Management in Japan
SOC225	Introduction to Japanese Society



## SECTION D : INFORMATION ON INSTRUCTORS & OFFICES § d100 TEACHING STAFF AND FACULTY OFFICE HOURS

**2017 - 2018**

Name	Area	Career
Tadashi Anno	Associate Professor, Political Science	B.A., University of Tokyo M.A., Ph.D., University of California, Berkeley
Akihito Asano	Associate Professor, Economics	B.A., Yokohama National University M.A., Hitotsubashi University M.Ec., Ph.D., Australian National University
Tina Burrett	Associate Professor, Political Science	B.A., Leeds University Mphil, Ph.D., Cambridge University
Kukhee Choo	Assistant Professor, Visual Media	B.S., M.A., University of Texas Ph.D. Tokyo University
Edward Drott	Associate Professor, Religion	B.A., M.A., Ph.D., University of Pennsylvania
Sandra Fahy	Associate Professor, Anthropology	B.A., M.A., York University, Ph.D., School of Oriental and African Studies, University of London
James C. Farrer	Professor, Sociology	B.A., University of North Carolina M.A., Ph.D., University of Chicago
Gary G. Fogal	Assistant Professor, Applied Linguistics	B.A., University of Windsor M.A., University of Guelph, M.A., University of New England Ph.D., University of Tronto
Bettina Gramlich-Oka	Professor, History	B.A., Tübingen Universität M.A., Sophia University Ph.D., Tübingen Universität
Parissa Haghirian	Professor, Business	B.A., M.A., University of Vienna M.A., Ph.D., Vienna University of Economics and Business Administration
Takuya Hasebe	Assistant Professor, Economics	B.A. Rutgers University Ph.D. City University of New York
Michio Hayashi	Professor, Art History	B.A., University of Tokyo M.A., Ph.D., Columbia University
Christian A. Hess	Associate Professor, History	B.A., University of California, Davis M.A., University of California, San Diego Ph. D., University of California, San Diego
Caroline Hirasawa	Associate Professor, Art History	B.A., Empire State College M.F.A., Tokyo University of Fine Arts M.A., Ph.D., Stanford University
Naoto Isaka	Associate Professor, Finance	B.A., Sophia University M.A., Osaka University Ph.D., Hitotsubashi University
Takeshi Ito	Associate Professor, Political Science	B.A., Keio University M.A., Hitotsubashi University M.A., M-Phil., Yale University Ph.D., Yale University
Yacob Khojasteh	Associate Professor, Business and Management	B.S., Iran University of Science and Technology M. Sc., Tarbiat Modares University M. Sc., Ph.D., University of Tsukuba
Yoshifumi Konishi	Associate Professor, Economics	B.A., Chuo University M.A., University of Pittsburg Ph.D., University of Minnesota



Shion Kono	Associate Professor, Literature	B.A., Bowdoin College M.A., Ph.D., Princeton University
Michiru Kosaka	Associate Professor, Economics	B.A., Hitotsubashi University M.A., Hitotsubashi University Ph.D., Duke University, Durham
Tatsushi Motohashi	Associate Professor, Linguistics	B.A., M.A., Sophia University Ph.D., University of Arizona
Noriko Murai	Associate Professor, Art History	B.A., University of California, Berkley M.A., Ph.D., Harvard University
Tatsuo Murakami	Associate Professor, Religion	B.A., Beloit College M.A., Syracuse University Ph.D., University of California, Santa Barbara
Koichi Nakano	Professor, Political Science	B.A., University of Tokyo B.A., University of Oxford M.A., Ph.D., Princeton University
Hanako Okada	Associate Professor, Applied Linguistics	B.A., Sophia University M.A., Ed.D., Temple University
Thierry-Jean Robouam, S.J.	Associate Professor, Religion	B.A., M.A., Sophia University S.T.D., Jesuit School of Theology at Berkeley
Sven Saaler	Professor, History	B.A., University of Cologne M.A., Ph.D., University of Bonn
David Slater	Professor, Anthropology	B.A., Vassar College M.A., Ph.D., University of Chicago
Matthew Strecher	Professor, Literature	B.A., M.A., University of Texas at Austin Ph.D., University of Washington
Yuka Sugawara	Assistant Professor, Sociology	B.A. Sophia University M.A. Harvard University Ph.D. University of Texas at Austin
Mathew Thompson	Associate Professor, Literature	B.A., Yale University M.A., Ph.D., Columbia University
Junko Uenishi	Associate Professor, Business	B.A., Harvard University M.S., M.B.A., Northeastern University
David L. Wank	Professor, Sociology	B.A., Oberlin College M.A., Ph.D., Harvard University
Takehiro Watanabe	Associate Professor, Anthropology	B.A., State University of New York at Albany M.A., The University of Chicago M.A., Ph.D., Columbia University
Robert E. Witmer	Professor, English	B.A., Ball State University M.A., Temple University
Angela Yiu	Professor, Literature	B.A., Cornell University M.A., Ph.D., Yale University

**Adjunct Instructors**

Eric Bossieux	Computer	B.A., Sophia University
Michael Burtscher	History	B.A., University of Washington, Seattle M.A., Ludwig-Maximilians-University, Munich, Germany
Mark Caprio	History	M.A., Ph.D., University of Washington
Nathalie Cavasin	Geography, Environmental Studies	B.A., M.A., University of Toulouse II-Le Mirail Ph.D., University of Toulouse II-Le Mirail
Philippe Stéphan Debroux	Business	B.A., Brussels Free University M.B.A., European Institute of Business Administration Ph.D., Brussels Free University
Arlene Dinglasan	English	B.S., Computer Science Adamson University, Manila M.A., in TESOL Temple University, Japan
Takeo Fujikura	Literature	B.A., M.A., State University of New York at Binghamton Ph.D., University of Wisconsin Madison
Patrick Galbraith	Anthropology	B.A., University of Montana M.A., Sophia University Ph.D., Duke University
Nicholas Goman	English	B.A., Macalester College M.F.A., Oregon State University
David Griffith	English	LLB, Victoria University of Wellington LLM, Ph.D., Auckland University
Brian Heagney	English	B.A., M.A., Trinity College, Dublin
Yoshihide Horiuchi	Business	B.A., Waseda University M.A., University of Illinois Ph.D., University of Pennsylvania
Shunsuke Kuwayama	English	B.A., Middlebury College M.A., Sophia University
Simon Liu	International Business, Corporate Strategy	B.E., National Taiwan University M.A., Ph.D., University of Tokyo
Olga Marina	English	B.A., Kishinev State University of the USSR M.A., National University of Singapore Ph.D., Academy of Teacher Development
David McNeill	Political Science	B.A., University of Ulster Ph.D., Napier University
Junko Murakami	Mathematics	B.A., M.A., University of Kansas Ph.D., Arizona State University
Maki Nakai	History	B.A., M.A., University of Tokyo Ph.D., University of Tokyo
Shunsuke Nozawa	Anthropology	B.A., New York University M.A., Ph.D., University of Chicago
Tomohito Okabe	Economics	B.A., M.A., Keio University M.A., Hosei University Ph.D., Australian National University
Jeremy Redlich	Literature	B.A., University of Victoria M.A., Ph.D., University of British Columbia
Serajejan Rossitto	Social Movement Theory	B.A., State University of New York at Purchase M.A., Columbia University
Mahendra Singh	Business	M.B.A., International University of Japan

Jordan Smith	Literature	B.A., University of California Santa Crus M.A., Ph.D., University of California Los Angeles
Toyohiko Sugimoto	Computer	B.A., Meiji University M.A., Yokohama National University, M.A., The University of Queensland
Dennis Tachiki	Business	B.A., University of California Los Angeles M.A., University of Michigan
Naoko Takii	Art	B.A., M.A., Waseda University M.A., University of Delaware
Akiko Tanaka	English	B.A., M.B.A., Golden Gate University, San Fransisco
Tomoko Tokunaga	Sociology	B.A., University of Tsukuba M.A., University of Tokyo Ph.D., University of Maryland
Kiyoshi Ueda	History	B.A., Missouri State University M.A., Ph.D., University of Toronto
Fumiko Umezawa	History	B.A., M.A., University of Tokyo
Nobue Urushihara-Urvil	English	B.A., M.A., Sophia University Ph.D., University of Texas Medical Branch at Galveston
Torsten Weber	History	B.A., Johannes Gutenberg-University Mainz M.A., University of London, Eberhard Karls-University Tübingen Ph. D., Ruprecht-Karls-University Heidelberg

**§ d110 FACULTY OFFICE HOURS - 2017**

A	Anno, Tadashi	(SPR)&(AUT) Tues. Fri. 1:00-2:30	10-525
	Asano, Akihito	(SPR)Sabbatical (AUT) Mon. Thurs. 12:45-1:45	10-555
B	Burrett, Tina	(SPR)&(AUT) Mon.12:30-1:30 or by appointment	10-522
C	Choo, Kukhee	(SPR)Tues. 3:30-4:30 (AUT)Fri.6:30-7:30	10-632
D	Drott, Edward	(SPR)&(AUT) Mon. 12:30-1:30 Thurs. 3:00-4:00 or by appointment	10-653
F	Fahy, Sandra	(SPR)&(AUT) Tues. 2:00-3:00	10-505
	Farrer, James	(SPR)&(AUT) Mon. 2:30-5:30 Wed. 8:45-9:15	10-503
	Fogal, Gary	(SPR)&(AUT) Tues. 12:00-1:00 or by appointment	10-601
G	Gramlich-Oka, Bettina	(SPR) Tues. 12:30-1:30 (AUT) Fri. 11:00-12:00 or by appointment	10-520
H	Haghirian, Parissa	(SPR)&(AUT) Mon. 12:30-1:30	10-535
	Hasebe, Takuya	(SPR)&(AUT) Mon.Thurs.3:15-4:15 or by appointment	10-553
	Hayashi, Michio	(SPR)& (AUT) Sabbatical	10-628
	Hess, Christian	(SPR)&(AUT) Thurs. 11:00-1:00 or by appointment	10-518
	Hirasawa, Caroline	(SPR)&(AUT) Mon. 12:30-1:30 or by appointment	10-630
I	Isaka, Naoto	(SPR) Tues. 3:00-4:00 (AUT) Tues. 10:15-10:45 or by appointment	10-543
	Ito, Takeshi	(SPR)& (AUT) Tues. 3:00-4:00 or by appointment	10-530
K	Khojasteh, Yacob	(SPR) Tues.Fri. 10:45-11:45(AUT) Tues.Fri. 10:00-11:00 or by appointment.	10-549
	Konishi, Yoshifumi	(SPR) Sabbatical (AUT)Mon.Thurs.5:00-6:00 or by appointment	10-547
	Kono, Shion	(SPR)&(AUT) Fri. 12:30-1:30 or by appointment	10-637
	Kosaka, Michiru	(SPR)Tues.Fri. 12:45-1:30 or by appointment (AUT)Sabbatical	10-541
M	Motohashi, Tatsushi	(SPR)&(AUT) Mon. 1:30-3:00	10-613
	Murai, Noriko	(SPR) Fri. 2:00-3:00 (AUT) Sabbatical	10-634
	Murakami, Tatsuo	(SPR)&(AUT) Tues. Fri. 3:00-4:00	10-655
N	Nakano, Koichi	(SPR) Mon. 11:30-11:45	Dean's Office
		(AUT) Mon. 1:30-2:30	
O	Okada, Hanako	(SPR) Tues. 3:00-4:00 (AUT) Mon. 3:15-4:15 or by appointment	10-603
R	Robouam, Thierry	(SPR)&(AUT)Sabbatical	10-657
S	Saaler, Sven	(SPR) Mon. 2:00-3:00 (AUT) Tues. 11:00-12:00 or by appointment	10-516
	Slater, David	(SPR)&(AUT) Mon3:00-5:00 or by appointment	10-509
	Strecher, Matthew	(SPR)& (AUT)Tues. 11:00-12:00 or by appointment	Chair's Office
	Sugawara, Yuka	(SPR)&(AUT) Tues. 11:00-12:30	10-501
T	Thompson Mathew	(SPR)&(AUT)Tues. 1:30-3:00 or by appointment	10-644
U	Uenishi, Junko	(SPR) Tues.Fri. 11:00-12:00 (AUT) Tues.Fri. 3:30-4:30 or by appointment	10-557
W	Wank, David	(SPR)Tues. 4:00-5:00 or by appointment (AUT) Sabbatical	10-512
	Watanabe, Takehiro	(SPR) Tues. Fri. 10:00-10:45 (AUT) Fri.1:30-3:00 or by appointment	10-514
	Witmer, Robert	(SPR)&(AUT) Tues. 11:00-12:00	10-605
Y	Yiu, Angela	(SPR)&(AUT) Fri. 3:00-4:00	10-647

## § d200 General Information and Office Directory

### § d210 International Students Coming to Japan

#### 1. Status of Residence

Students who do not hold Japanese citizenship must have as their status of residence "college student" or other appropriate status such as "permanent resident", "long term resident", or "dependent". A temporary visitor visa is not acceptable.

To qualify for status as a "college student", students are required to register for at least 4 regular courses (i.e., at least 10 hours of class time per week).

#### 2. Extension of Period of Stay as “College Student” / Change of Status of Residence to “College Student”

For procedures on extending the period of stay or changing the status of residence, please refer to the Sophians' Guide 2017. Please note that among the documents submitted to the Immigration Bureau, there are forms that must be filled out by the Center for Academic Affairs, which take about 4 days to be issued.

After your application is approved:

1. Register the changes in your status of residence at the residential municipal office within 14 days.
2. Submit a photocopy of the updated "Resident Card" to the Center for Academic Affairs, Academic Records Section as soon as possible.

※ Various disadvantages regarding school life, such as restricting access to Loyola or the non-receipt of scholarships, may occur until the necessary documents are submitted.

### § d220 Lost and Found

A lost-and-found service is provided at the Office of Property (Bldg. No.2, 1F). If a student loses or finds an article, it should be reported to this office.

### § d230 Parking Facilities

The University has no parking facilities for students on campus. Students are advised not to drive any vehicle to the university. Tokyo municipal law strictly prohibits the parking of cars, motorcycles or bicycles on public streets around campus.

### § d240 Scholarships and Financial Aid Programs

University scholarship, as well as many scholarships offered by public or private institutions are available for Japanese and international students. Detailed information is given on the Sophia University website and the online Bulletin Board of the Center for Student Affairs on Loyola.

General Information: <http://www.sophia.ac.jp/eng/financial/scholarships>

---

### § d250 Health and Insurance

#### -National Health Insurance System

International students who will stay in Japan for more than three months are required to join this insurance system. The procedures are carried out at the student's local ward/city office.

#### -Personal Accident Insurance for Students Pursuing Education and Research

All degree students and exchange students must be affiliated with this insurance plan. This plan covers physical injuries a student suffers during prescribed educational and research activities at the University and during commuting to school and in transit between school facilities.

Additional information can be found in the Sophians' Guide 2017.

### § d260 Medical Check-up

All new degree students must have a medical check-up at the beginning of their first semester followed by check-ups every year in April. The dates and place for the medical check-up will be announced on the Loyola Bulletin Board.

### § d270 Other Information

#### -Sophia University Academic Excellence Awards

These awards are available to undergraduate sophomores, juniors and seniors who show high academic performance. Grantees are decided upon recommendation from the Dean of each faculty.

#### -Housing

Sophia University has several off-campus dormitories available to all students.

#### -Counseling Services

Individual and group counseling is available from professional counselors to help students resolve any problems they may encounter during their college life (e.g. academic concerns, career options, student life, relationship issues, and mental and emotional health). Counseling is available both in English and in Japanese, and the services are free of charge. Disclosed information is kept confidential. All Sophia University students are invited to utilize the services. To see a counselor, please make an appointment either in person or by phone. The Counseling Center is located on 3F, Bldg. 10.

#### -Campus Ministry

The Catholic Center offers an English Mass on Tuesdays (1F, Bldg. 2).

For more details, please refer to the Sophians' Guide 2017 available at the Center for Student Affairs.

## § d280 OFFICE DIRECTORY

**OFFICE HOURS: Mon -Fri 9:30~11:30 AM, 12:30~5:00 PM**

- ※ Services are available only during the above office hours for providing information, and accepting applications and required documents.
- ※ Offices are closed on Saturdays, Sundays and national holidays.
- ※ Office hours during summer and winter vacations and on special circumstances are announced on the Loyola Bulletin Board for the Center for Academic Affairs (Academic Services).

	Office	Tel	Bldg	Floor
Course Registration / Class Information / Transfer Credits / Examination / Grades	Center for Academic Affairs	03-3238-3515	No. 2	1F
Tuition and Fees	Center for Academic Affairs	03-3238-3195	No. 2	1F
Request for Leave of Absence Request for Withdrawal from the University I.D. Card Re-issuance Change of Address / Guarantor Re-admission Transfer of Faculty / Department	Center for Academic Affairs (Academic Records Section)	03-3238-3519	No. 2	1F
Student Travel Fare Discount Certificates Certificate of Enrollment / Official Transcript	Vending Machine		No. 2	4F
Student Counseling, Clubs & Circles Extra-curricular Activities & Volunteering Insurance, Part-time Jobs, Assistance for Students with Disabilities, etc Applications for Nursery & Prayer Room	Center for Student Affairs	03-3238-3525	No. 2	1F
Dormitory		03-3238-4621		
Financial Support (Scholarship)		03-3238-3523		
Lost & Found	Office of Property	03-3238-3112	No. 2	1F
Exchange Program (Incoming / Outgoing) Short-term Language Programs Short-term Study Abroad Programs Social Engagement Programs Study Abroad Insurance Monbukagakusho Scholarship	Center for Global Discovery	03-3238-3521	No. 2	1F
Global Competency Program, Internship Courses Sophia Short-term Programs	Center for Global Discovery	03-3238-3737 03-3238-4090	No. 2	B1F
Employment / Internship	Career Center	03-3238-3581	No. 2	1F
Admissions	Admissions Office (Undergraduate) (Graduate)	03-3238-4018 03-3238-3517	No. 2	1F
Appointment with Dean / Chair / Director	FLA / GPGS Office	03-3238-4004	No. 10	4F
Health Services	Health Center	03-3238-3394	Hoffman Hall	2F
Resources	Library	03-3238-3510	Central Library	1F
Consultation / Application for using Computer, e-Learning, Mail, Network, etc.	Media Center <a href="http://ccweb.cc.sophia.ac.jp">http://ccweb.cc.sophia.ac.jp</a>	03-3238-3101	No. 2	3F
Counseling	Counseling Center	03-3238-3559	No. 10	3F
Teacher and Curator Certification Programs	Center for Teaching and Curator Credentials	03-3238-3520	No. 2	1F
Campus Ministry	Catholic Center	03-3238-4161	No.2	1F

### Personal Information

For policy on the protection of personal information of Sophia School Corporation, visit the following site:  
[http://www.sophia.ac.jp/jpn/info/privacypolicy/joho\\_toriatsukai](http://www.sophia.ac.jp/jpn/info/privacypolicy/joho_toriatsukai)



### Yotsuya Campus 四谷キャンパス

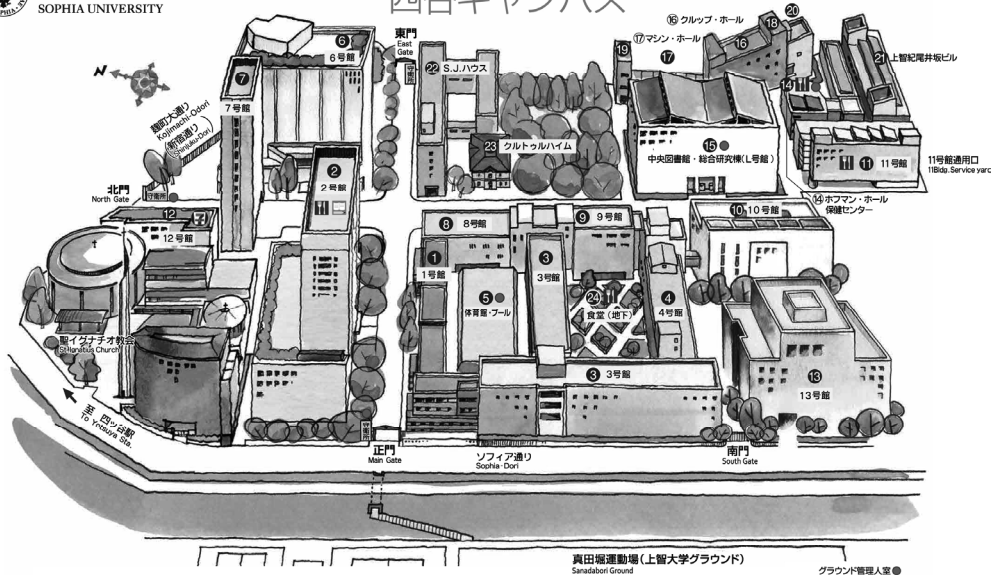

- |                     |                    |                                      |                                  |   |
|---------------------|--------------------|--------------------------------------|----------------------------------|---|
| ● 1号館 Bldg. No.1    | ● 6号館 Bldg. No.6   | ● 12号館 Bldg. No.12                   | ● クループ・ホール Krugg Hall            | ● S.J.ハウス S.J. House  |
| ● 2号館 Bldg. No.2    | ● 7号館 Bldg. No.7   | ● 13号館 Bldg. No.13                   | ● マシン・ホール Machine Hall           | ● クルトゥルハイム Kulturheim                                       |
| ● 3号館 Bldg. No.3    | ● 8号館 Bldg. No.8   | ● ホフマン・ホール Hoffmann Hall             | ● パワーステーションI Power Station I     | ● 購買 紀伊國屋書店 上智大学店 地下 (basement)                             |
| ● 4号館 Bldg. No.4    | ● 9号館 Bldg. No.9   | ● 保健センター Health Center               | ● パワーステーションII Power Station II   | ● 食堂 Restaurant 5階 (5F) 地下 (basement) 4階 (4F) 地下 (basement) |
| ● 5号館 Gymnasium     | ● 10号館 Bldg. No.10 | ● 中央図書館 Central Library              | ● パワーステーションIII Power Station III | ● AED (自動体外式除細動器) : 学内6ヶ所 Automated External Defibrillator  |
| ● プール Swimming Pool | ● 11号館 Bldg. No.11 | ● 総合研究棟(L号館) and Research Institutes | ● 上智紀尾井坂ビル Jochi Kioizaka Bldg.  | ● コンビニエンスストア Convenience Store 地下 (basement)                |

#### ● 市谷キャンパスアクセスガイド Ichigaya Campus Access Guide





# Yotsuya Campus

## Bulletin Boards in Building No.2 1F

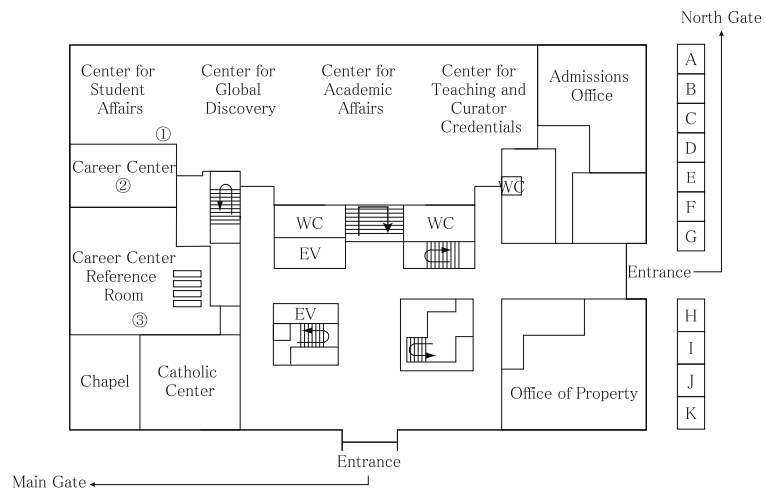

- |   |                            |   |                               |
|---|----------------------------|---|-------------------------------|
| ① | Center for Student Affairs | A | Admissions Office             |
| ② | } Career Center            | B | } Campus Membership           |
| ③ |                            | C |                               |
|   |                            | D |                               |
|   |                            | E | } Center for Academic Affairs |
|   |                            | F |                               |
|   |                            | G |                               |
|   |                            | H | } Center for Student Affairs  |
|   |                            | I |                               |
|   |                            | J | Career Center                 |
|   |                            | K | Center for Global Discovery   |

**Building No.1,3,4,8,9**

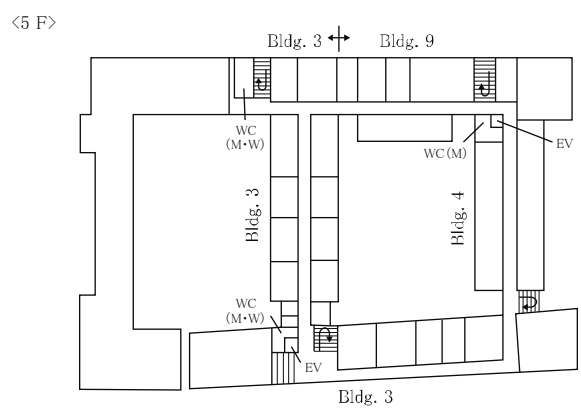
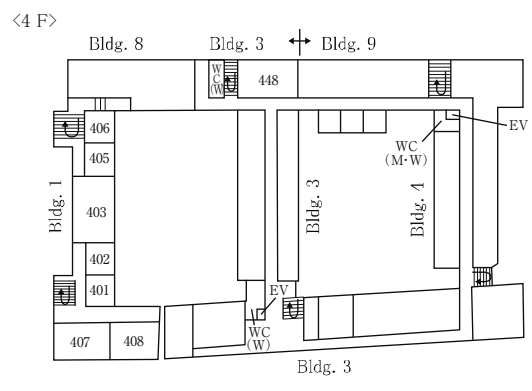
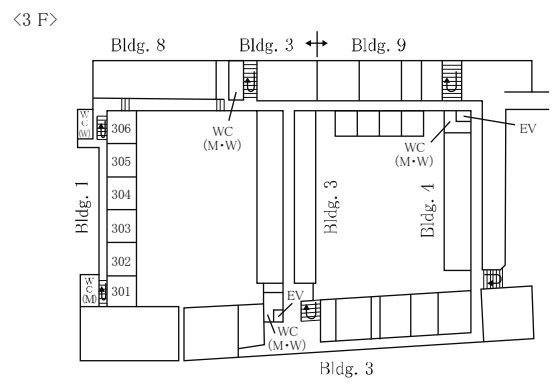
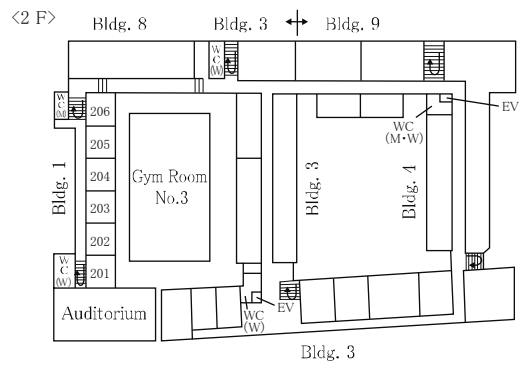
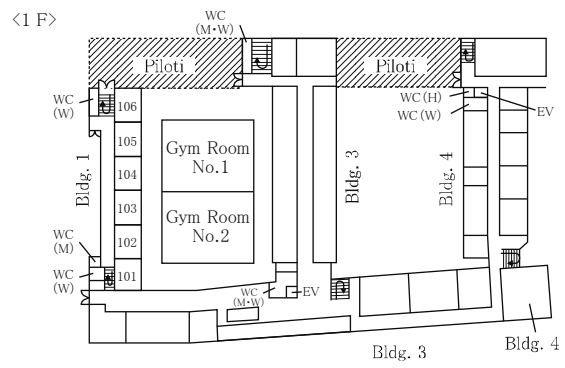

**Building No.2**

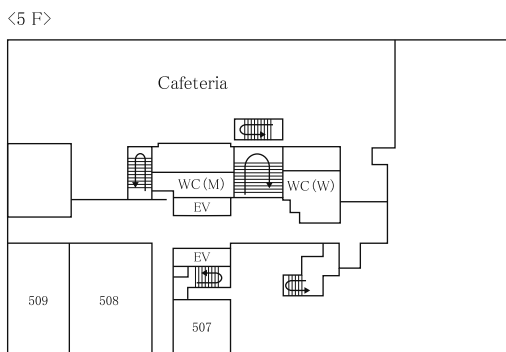
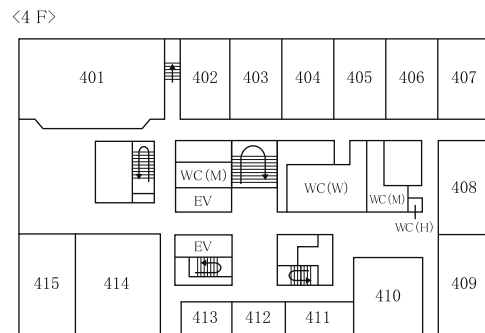
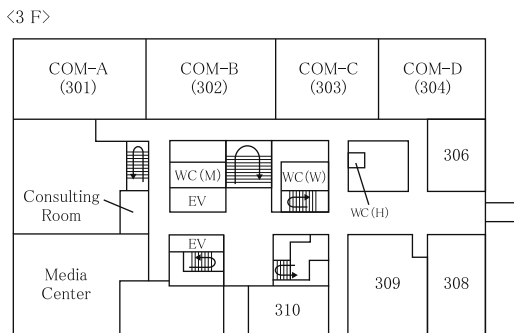
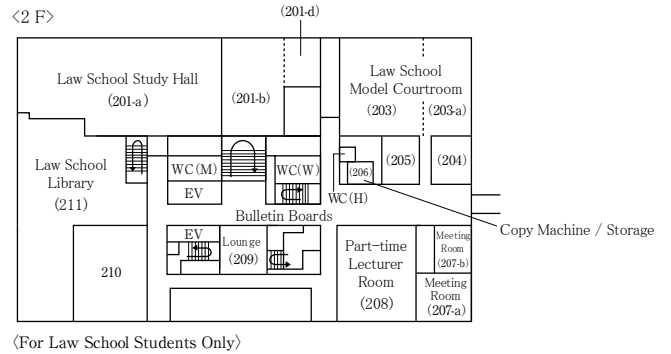
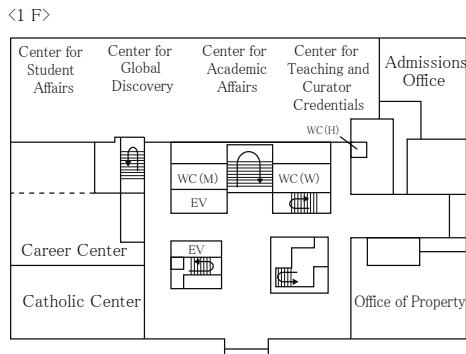
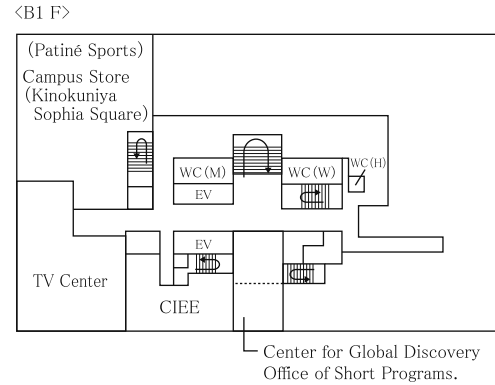
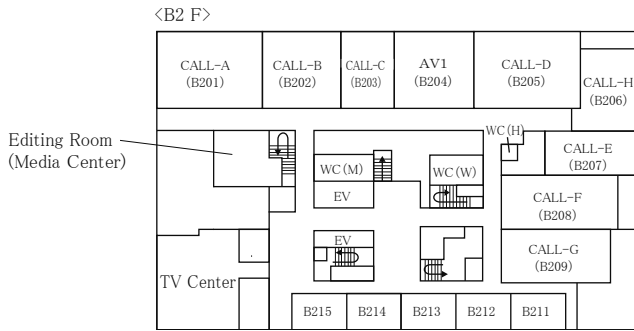

### Building No.6

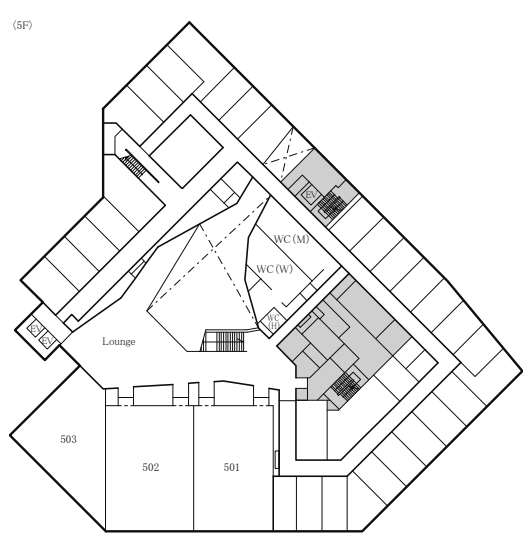
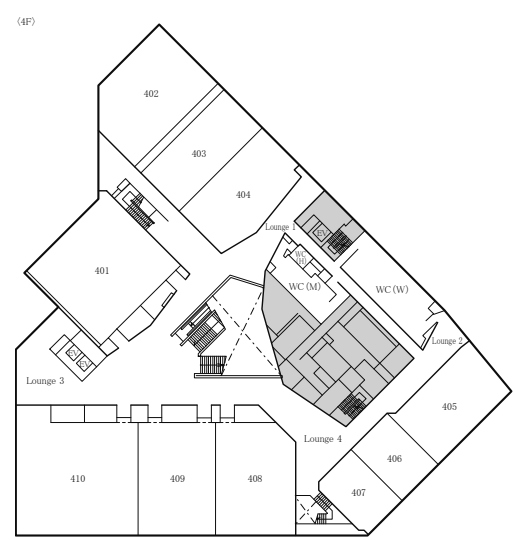
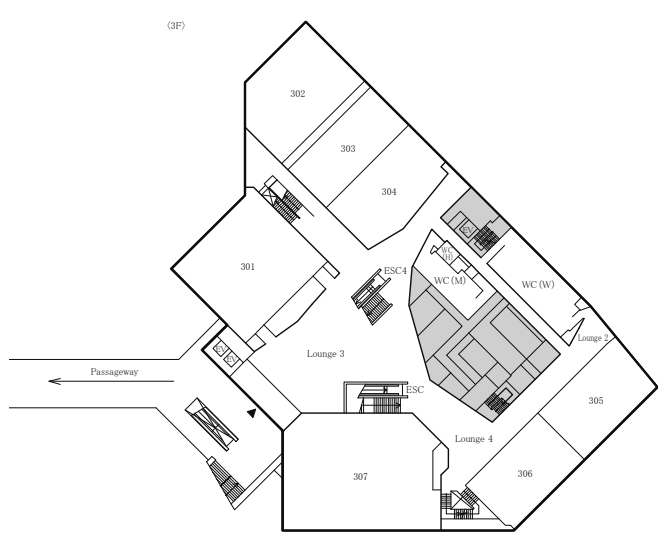
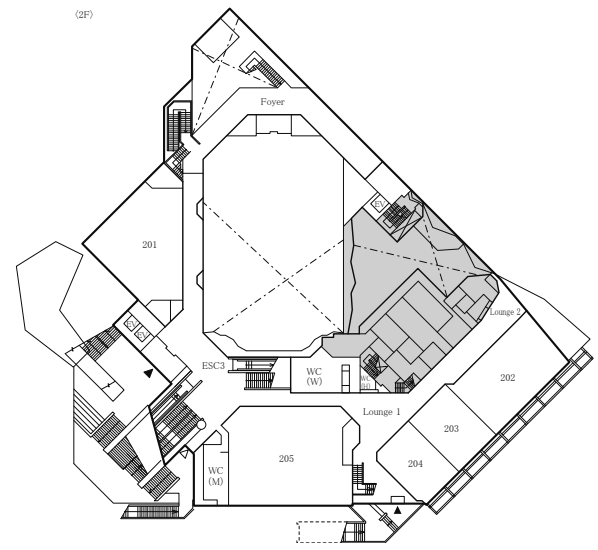
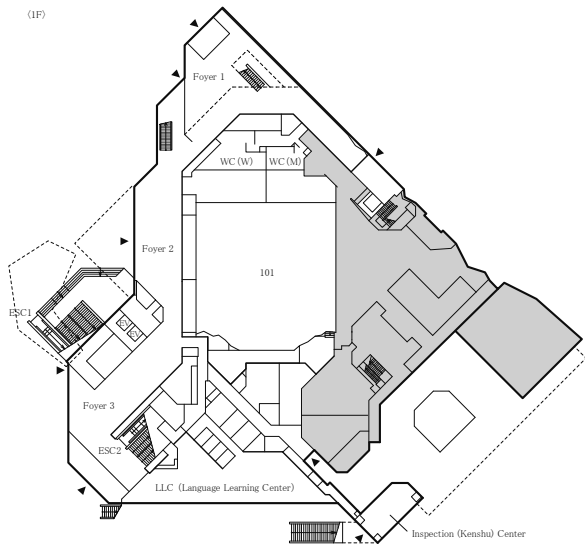

**Central Library (Building L)**

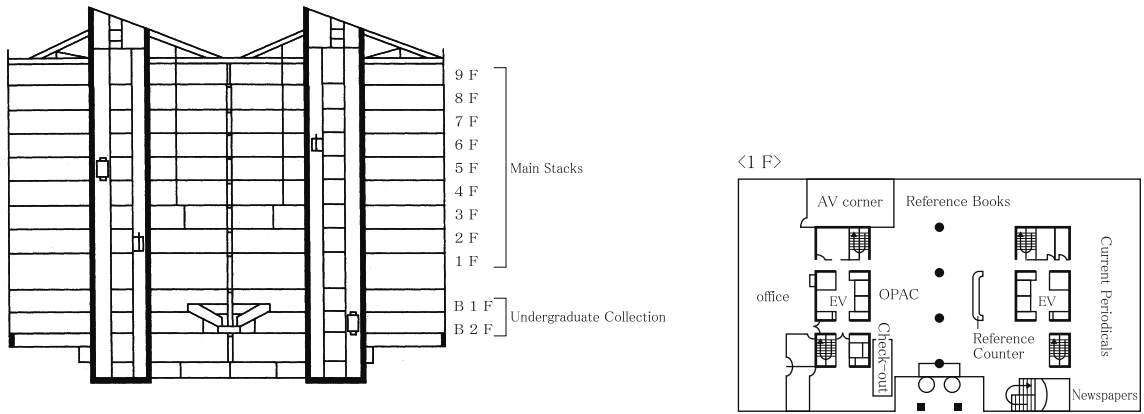

**Building No.10**

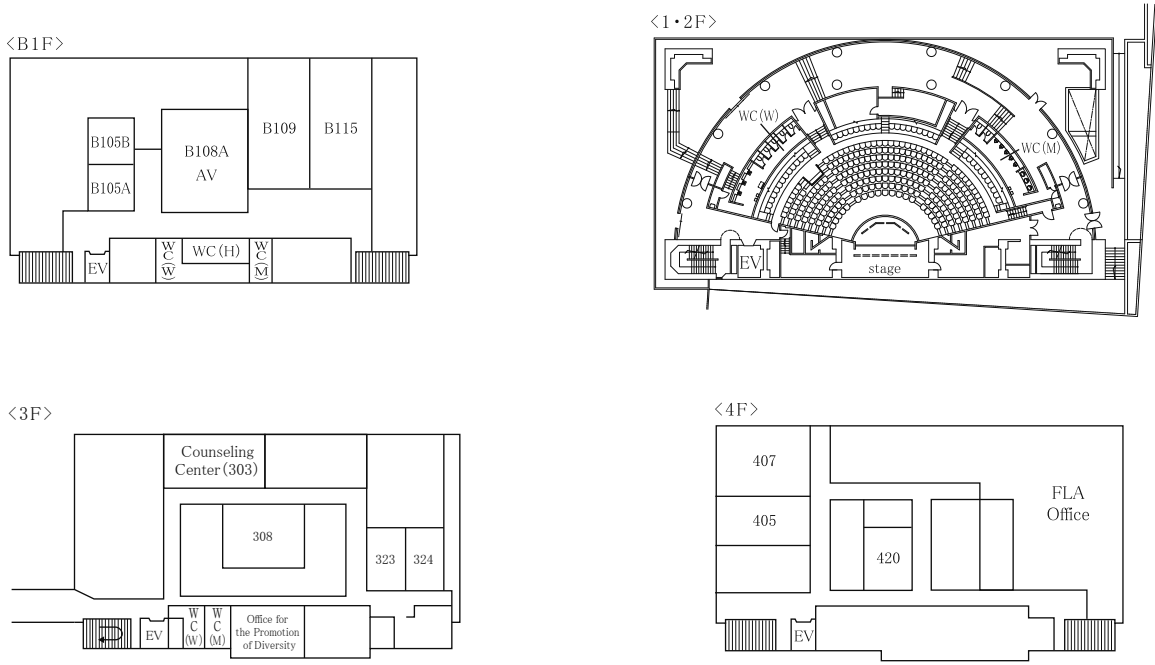

### Building No.11 & Jochi Kioizaka Building

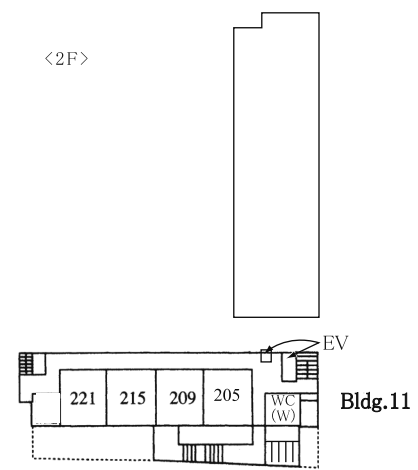
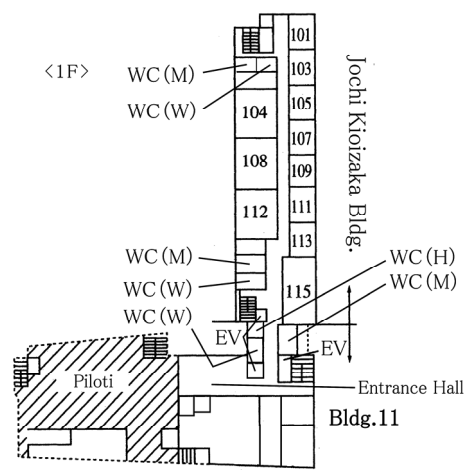
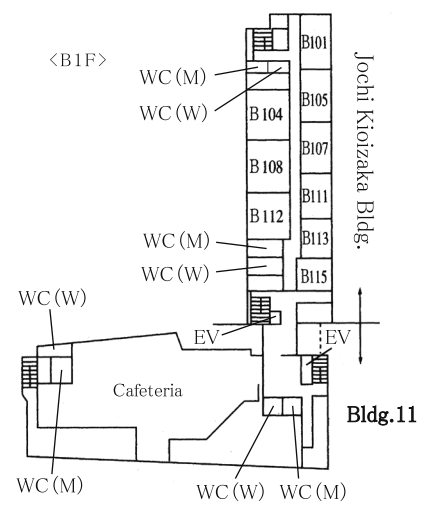
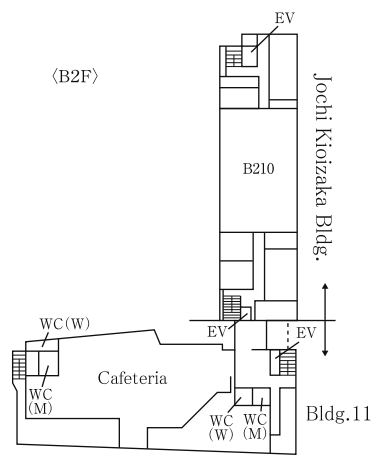

**Building No.11**

< 3 F >

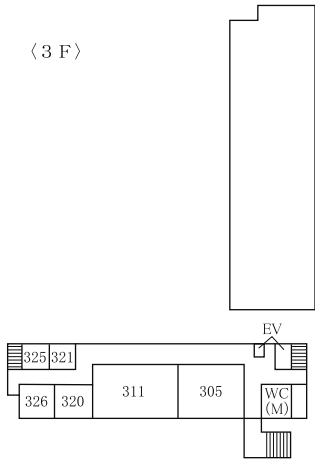

< 4 F >

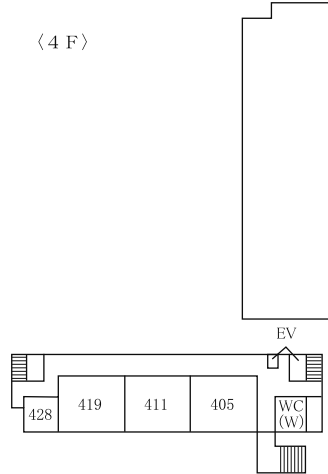

< 5 F >

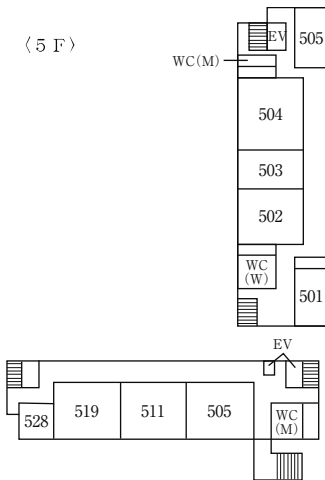

< 6 F >

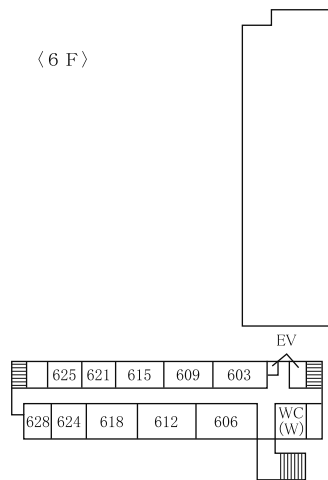

< 7 F >

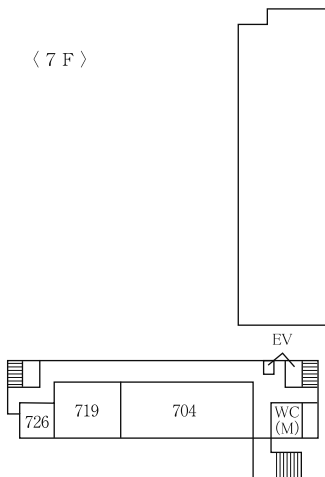

### Building No.12

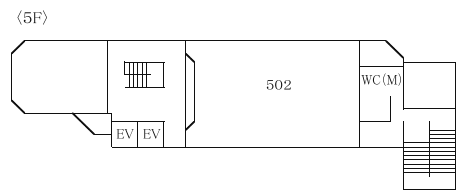
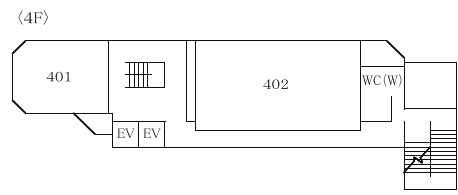
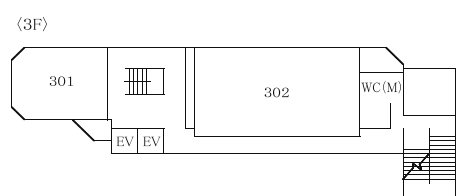
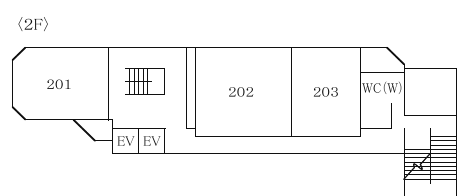
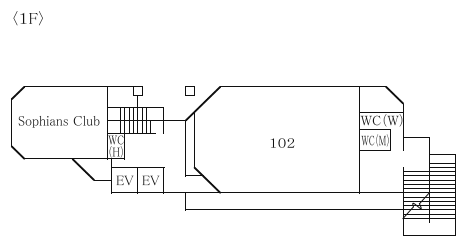
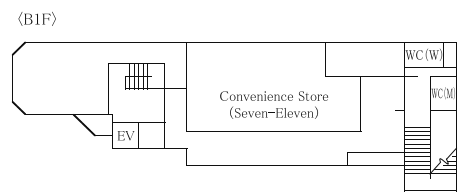

### Krupp Hall / Machine Hall

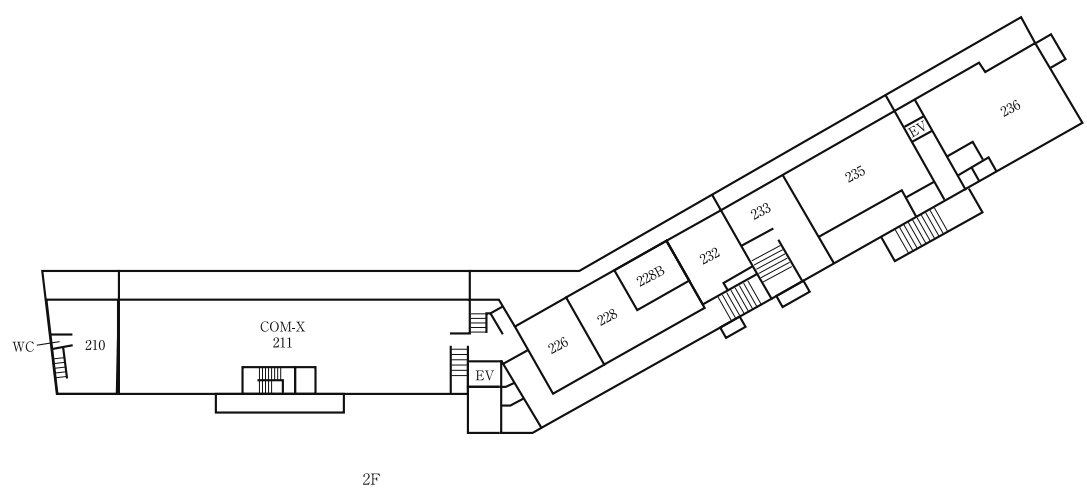
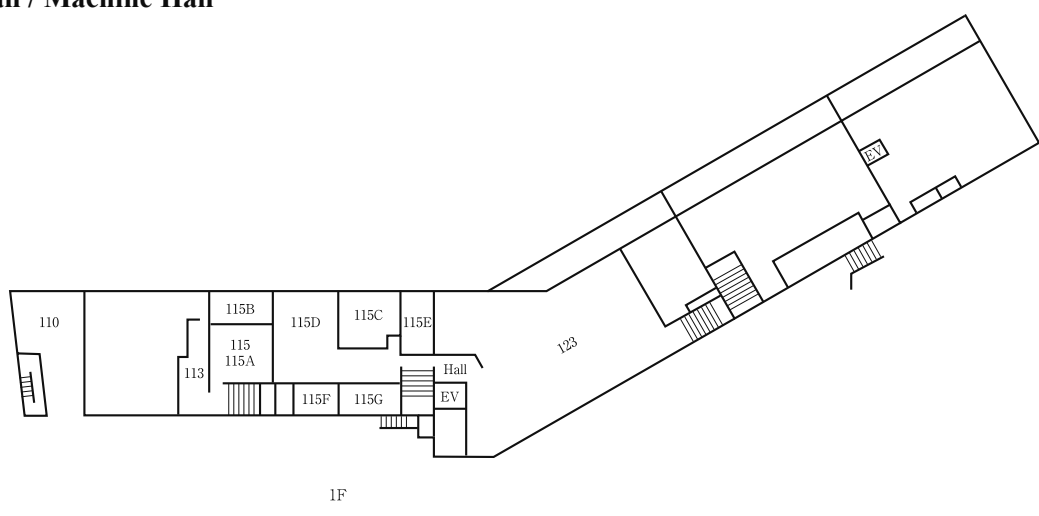



# Ichigaya Campus

## Main Building

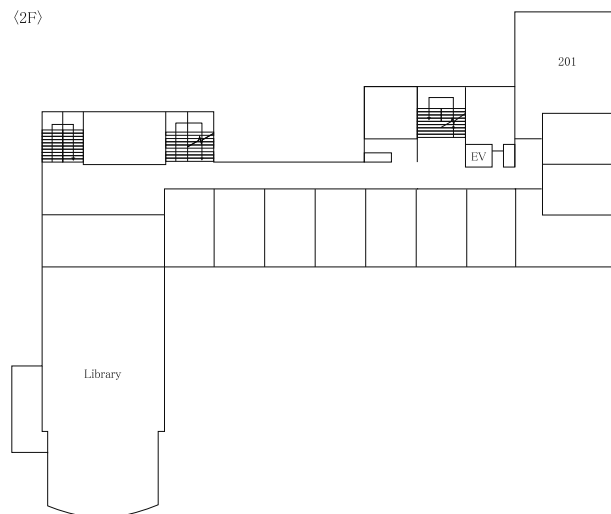
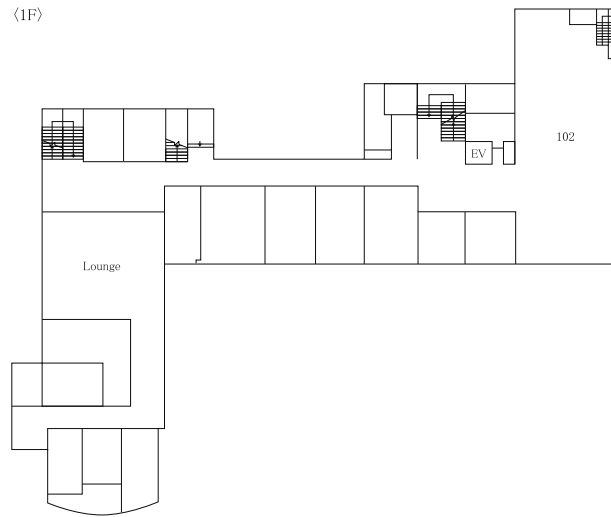

## Research Building

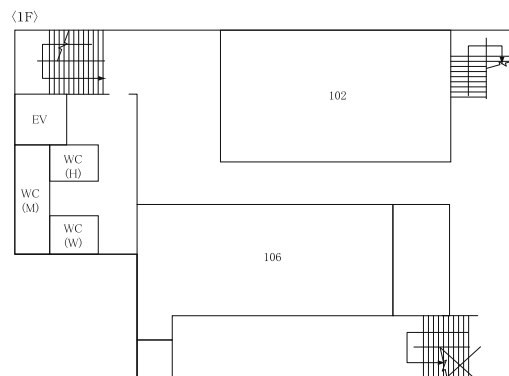

**INDEX**

Academic Dishonesty	§ a440
Admission for a Second Degree	§ a660
Advanced General Education Courses	§ b123
Advising	§ a312
Attendance at Classes	§ a560; § a980; § a990 - § a994
Bulletin Boards	§ a910
Certificates	§ a930
Certificate Programs	§ c200
Certification Programs	§ a750
Change of Faculty	§ a640
Cheating	§ a441
Christian Humanism	§ b111; § b231
Comparative Culture	§ b151; § b261
Core Program Courses	§ a340; § b141; § b251
Counseling Services	§ d270
Course Cancellation	§ a364
Course Conflict	§ a314
Course Registration	§ a300; § b131; § b132; § b133; § b134
Course List (FLA)	§ b310
Course List (Language Courses)	§ b330
Course Numbering	§ b011
Course Registration (Procedure and Schedule)	§ a310
Course Withdrawal	§ a310; § a365; § b130; § b232
Dismissal from University	§ a630 - § a633
Distribution Courses	§ b121; § b241
Early Graduation	§ a260
English Placement Test	§ b141; § b251
Examinations	§ a400
Exchange Program	§ a710
Faculty Office Hours	§ d110
General Courses	§ b122; § b242
General Studies	§ b110; § b230
General Studies Electives	§ b113; § b235
Grades	§ a500
Grade Point Average (GPA)	§ a520
Grade Review	§ a530
Guarantor	§ a952
Health & Physical Education	§ b112; § b233
Honors	§ a550
Housing	§ d270

Infectious Diseases	§ a980
Information on Curriculum	§ b010
Insurance	§ d250
International Business & Economics	§ b152; § b262
International Students	§ d210
Japanese Language Program (JLP)	§ b340
Japanese Studies Certificate	§ c210
Language Courses	§ a352; § b130;b232
Lay Judge Service	§ a990
Leave of Absence	§ a610; § a825
Lost & Found	§ d220
Lottery Courses	§ a330
Loyola Web Service	§ a130
Major Courses	§ b142; § b150; §b252; §b260
Make-up Exams	§ a450
Make-up Exam Fee	§ a453
Plagiarism	§ a442
Public Transport Service is Shut Down	§ a970
Re-admission	§ a650
Residence Requirements	§ a220
Scholarships & Financial Aids	§ d240
SE Electives	§ b143; §b253
Short-term Language Programs	§ a712
Short-term Study Abroad Programs	§ a713
Social Engagement Programs	§ a714
Social Studies	§ b153; §b263
Specialized Education	§ b140 ;§b250
Specialized Education Electives	§ b143; §b253
Student Identification Card	§ a940
Studies in Christian Humanism	§ b111; §b231
Summer Session	§ c101
Transfer of Credits	§ a270
Transfer of Residency	§ a270
Transfer Students	§ a270
Tuition and Fees	§ a800
Withdrawal from Courses	§ a365
Withdrawal from University	§ a630
Office Directory	§ d280